



**KTH Architecture and
the Built Environment**

Vibration transfer process during vibratory sheet pile driving – from source to soil

Fanny Deckner

Doctoral thesis

Division of Soil and Rock Mechanics
Department of Civil and Architectural Engineering
School of Architecture and the Built Environment
KTH Royal Institute of Technology
Stockholm 2017

TRITA-JOB PHD 1026
ISSN 1650-9501
ISBN 978-91-7729-315-6

©Fanny Deckner
2017

Akademisk avhandling som med tillstånd av KTH i Stockholm framlägges till offentlig granskning för avläggande av teknologie doktorsexamen fredagen den 5 maj 2017 kl 13.00 i Kollegiesalen, KTH, Brinellvägen 8, Stockholm. Avhandlingen försvaras på engelska.

PREFACE

The work presented in this doctoral thesis was conducted between September 2009 and January 2017 at NCC Engineering and the Division of Soil and Rock Mechanics at KTH Royal Institute of Technology in Stockholm, Sweden. The work has been supervised by Prof. Staffan Hintze and Dr. Kenneth Viking, and financial support has been provided by the Development Fund of the Swedish Construction Industry (SBUF), NCC AB, Hercules Grundläggning and KTH.

I would like to express my deepest gratitude to my supervisors Staffan and Kenneth. You initiated the project and believed in me. Your support, commitment, guidance and encouragement have been invaluable.

Further acknowledgements are dedicated to the Kents (Kent Allard and Kent Lindgren). Without these gentlemen's experience and knowledge, the field test in Solna in 2013 would not have been half as good as it was. My hardworking master thesis students also need a mention: Märta, Claire and Thomas, the work you did helped me a lot in my progress.

The reference group for this project (Johan Blumfalk, Hercules; Jörgen Johansson, NGI; Olle Båtelsson, Trafikverket; Håkan Eriksson, GeoMind; Ulf Håkansson, Skanska/KTH and Nils Rydén, Peab/LTH/KTH) is gratefully acknowledged. Apart from great lunches, you contributed valuable discussions and input throughout the process. I would particularly like to thank Jörgen who patiently answered all my questions as I was struggling with the numerical part of this thesis.

I also want to thank Prof. Stefan Larsson and the others in the division of Soil and Rock Mechanics at KTH for letting me be a part of your group and guiding me on my path through extremely useful discussions.

To my wonderful colleagues at NCC Engineering, thank you so much for all the support, comfort and laughs over the years.

And finally, without the love and support of my family this would not even have been possible. Joel, Henry and Nora, what a journey it has been – you are truly wonderful.

Stockholm, February 2017

Fanny Deckner

SUMMARY

Retaining walls are a necessity in many urban construction projects today. Vibratory driven sheet piles are a cost-effective retaining wall structure, and in coming decades the continued use of vibratory driven sheet piles will be crucial for minimising costs within the construction sector. However, vibratory driven sheet piles are a source of ground vibrations, which may harm structures or induce disturbance. Most urban construction projects face strict limits on permissible vibration level. If the risk of exceeding limits is large, when using sheet piles, contractors are referred to costlier and more time-consuming retaining wall methods. Being able to reliably predict the expected vibration level prior to construction is therefore highly important if vibratory driven sheet piles are to be used in urban areas in the future. Reliable prediction demands a profound knowledge of the vibration transfer process, from source to point of interest. This thesis focuses on clarifying the vibration transfer process and will serve as a platform for the future development of a reliable prediction model.

The vibration transfer process is divided into three main parts: vibration source, vibrations in soil and nearby objects. This thesis is limited to a study of the first two. The vibrations generated at the source depend on the driving equipment, the sheet pile behaviour and the vibration transfer from sheet pile to soil. During vibratory driving, a vibrator is attached to the sheet pile with a clamp, usually holding the sheet pile in the web (eccentric clamping). The behaviour of the sheet pile during driving is mainly governed by its geometry, the eccentric clamping and the driving frequency. The transfer of vibrations from sheet pile to soil is largely controlled by the disturbed soil in the zone right next to the sheet pile. Slippage and large strains give a low shear modulus and high damping in this zone. The vibrations in soil are characterised by propagating waves induced by the driving, known as the wave pattern. The different parts in the vibration transfer process are studied and investigated with the help of a literature review, field tests and numerical modelling.

Within the scope of this thesis, three field tests have been conducted and a new instrumentation system has been developed. The new instrumentation system, which was used in the last two tests, enables recording of both sheet pile vibrations and ground vibrations at depth during the entire driving. The field tests aimed to study the vibration transfer from sheet pile to soil and the vibration transfer within a sheet pile wall, as well as the wave pattern in soil. To study sheet pile behaviour during driving a numerical model was developed, which is also meant to serve as a basis for further studies. The modelling uses 3D FEM and is unique in that it involves true sheet pile geometry and an equivalent linear soil model to account for strain dependency.

The main scientific contribution of this thesis is the identification of the sheet pile behaviour during driving. For practical application, the main contribution is the development of an increased knowledge of the vibration transfer process from source to soil, together with the new instrumentation system and the development of the numerical model.

Keywords: ground vibrations, sheet piles, vibratory driving, vibration transfer process, instrumentation system, field tests, numerical modelling, vibration prediction

SAMMANFATTNING

Stödkonstruktioner är en nödvändighet i många byggprojekt i tätbebyggda områden. Vibrodriven spont är en kostnadseffektiv stödkonstruktion och i framtiden kommer den fortsatta användningen av denna metod att vara nödvändig för att minimera kostnader för byggprojekt. Vibrodriven spont är dock en källa till markvibrationer, som kan skada byggnader eller orsaka störningar. De flesta byggprojekt måste förhålla sig till strikta krav gällande vibrationsnivåer. Om risken att överstiga vibrationsnivåerna anses för hög är entreprenörerna hänvisade till andra, mer kostsamma och tidskrävande, stödkonstruktioner. Möjligheten att på ett tillförlitligt sätt förutsäga vibrationsnivåerna innan bygget startar är därför av största vikt om vibrodriven spont fortsatt ska kunna användas i tätbebyggda områden. Tillförlitlig prognos av vibrationsnivåer i samband med vibrodrivning av spont kräver god kännedom om vibrationsöverföringsprocessen, från källan till det potentiella skadeobjektet. Denna avhandling fokuserar på att förtydliga vibrationsöverföringsprocessen och fungera som en plattform för framtida utveckling av en tillförlitlig prognosmodell.

Vibrationsöverföringsprocessen delas in i tre huvuddelar; vibrationskällan, vibrationer i jord och närliggande objekt. I denna avhandling studeras de två första. Vibrationerna som genereras vid källan beror av drivutrustningen, spontens beteende samt överföringen mellan spont och jord. Vid vibrodrivning används en vibrator, utrustad med en kraftig klämma som håller fast i spontens liv (excentrisk fasthållning). Spontens beteende styrs i huvudsak av dess geometri, den excentriska fasthållningen samt drivfrekvensen. Överföringen av vibrationer från spont till jord kontrolleras till stora delar av den störda zonen i jorden närmast sponten. Glidning och stora töjningar ger en låg skjuvmodul och hög dämpning i denna zon. Vibrationerna i jorden karaktäriseras av propagerande vågor, det så kallade vågmönstret. De olika delarna av vibrationsöverföringsprocessen studeras och undersöks med hjälp av litteraturstudie, fältförsök och numerisk modellering.

Inom ramarna för denna avhandling har tre fältförsök utförts och ett nytt instrumenteringssystem har utvecklats. Det nya instrumenteringssystemet användes i två av fältförsöken, och möjliggör mätning av både spontvibrationer och vibrationer på djup i jorden, under hela neddrivningsfasen. Fältförsöken syftade till att studera vibrationsöverföringen mellan spont och jord, vibrationsöverföringen inom en spontvägg samt vågmönstret i jorden under drivning. För att studera spontens beteende under neddrivning utvecklades en numerisk modell, som också kan fungera som en bas för framtida studier. Modellen är unik såtillvida att den använder sig av verklig spontgeometri samt en ekvivalent-linjär jordmodell för att ta hänsyn till töjningsberoende.

Avhandlingens huvudsakliga vetenskapliga bidrag är identifieringen av spontens beteende under neddrivning. För praktisk tillämpning är det huvudsakliga bidraget förklaringen av vibrationsöverföringsprocessen från källa till jord, det nya instrumenteringssystemet samt utvecklingen av den numeriska modellen.

Nyckelord: markvibrationer, spont, vibrodrivning, vibrationsöverföringsprocessen, instrumenteringssystem, fältförsök, numerisk modellering, vibrationsprognostisering

LIST OF NOTATIONS

Key symbols used in the text are listed below.

Greek Symbols

Symbol	Represents	Unit
α	Absorption coefficient	m^{-1}
γ	Shear strain	-
ζ	Hysteretic damping ratio	-
η_s	Isotropic loss factor	-
ν	Poisson's ratio	-
π	Pi	-
ρ	Density	kg/m^3
τ	Shear stress	kPa
ω	Angular frequency	rad/s

Roman Symbols

Symbol	Represents	Unit
A	Amplitude	m
G	Shear modulus	MPa
G_{equ}	Equivalent shear modulus	MPa
$G_{equ_slippage}$	Equivalent shear modulus with respect to slippage	MPa
G_{max}	Maximum shear modulus	MPa
m	Mass	kg
n	Coefficient depending on wave type	-
R_t	Toe resistance	kN
r	Distance from source	m
r_e	Eccentricity	m
t	Time	s
u	Displacement	mm

LIST OF PUBLICATIONS

This doctoral thesis is based on the work presented in the following publications.

Appended papers:

Paper I Deckner, F., Viking, K. and Hintze, S. (2012). Ground vibrations due to pile and sheet pile driving – prediction models of today. *Proceedings of the European Young Geotechnical Engineers Conference, 26-29 August, Gothenburg, Sweden. Peer-reviewed conference paper*

Deckner performed the analyses and wrote the paper. Hintze and Viking supervised the work and contributed valuable comments.

Paper II Deckner, F., Viking, K., and Hintze, S. (2015). Aspects of Ground Vibrations due to Pile and Sheet Pile Driving. *Electronic Journal of Geotechnical Engineering, Vol. 20, Bund. 19, pp. 11161-11176. Journal paper*

Deckner performed the analyses and wrote the paper. Hintze and Viking supervised the work and contributed valuable comments.

Paper III Deckner, F., Guillemet, C., Viking, K. and Hintze, S. (2015). Instrumentation System for Ground Vibration Analysis during Sheet Pile Driving. *Geotechnical Testing Journal, Vol. 38, No. 6, pp. 893-905, DOI: 10.1520/GTJ20140275. Journal paper*

Deckner, Guillemet and Viking developed equipment, planned the field test and took part in it. Deckner and Guillemet performed the analyses. Deckner wrote the paper. Hintze and Viking supervised the work and contributed valuable comments.

Paper IV Deckner, F., Viking, K. and Hintze, S. (2015). Vibration transfer during vibratory sheet pile driving – a full-scale field test. *Proceedings of the 6th International Conference on Earthquake Geotechnical Engineering, 1-4 November, Christchurch, New Zealand. Peer-reviewed conference paper*

Deckner and Viking developed equipment, planned the field test and took part in it. Deckner performed the analyses and wrote the paper. Hintze and Viking supervised the work and contributed valuable comments.

Paper V Deckner, F., Viking, K. and Hintze, S. (2016). Wave patterns in the ground – case studies related to vibratory sheet pile driving. *Geotechnical and Geological Engineering. (In review) Journal paper*

Deckner and Viking planned the field tests and took part in them. Deckner performed the analyses and wrote the paper. Hintze and Viking supervised the work and contributed valuable comments.

Paper VI Deckner, F., Johansson, J., Viking, K. and Hintze, S. (2016). Sheet pile behavior during vibratory driving: numerical study based on a field test. *Soil Dynamics and Earthquake Engineering. (Submitted December 2016) Journal paper*

Deckner and Johansson developed the model and performed the analyses. Deckner wrote the paper. Hintze and Viking supervised the work and contributed valuable comments.

Related publications:

Deckner, F., Hintze, S. and Viking, K. (2010). Miljöanpassad pål- och spontdrivning i tätbebyggda områden. *Bygg & teknik*, Vol. 102, No. 1. (In Swedish)

Lidén, M. (2012). *Ground Vibrations due to Vibratory Sheet Pile Driving*. Division of Soil- and Rock Mechanics, KTH Royal Institute of Technology, Stockholm, Sweden, Master of Science Thesis 12/06.

Deckner supervised the master thesis work.

Deckner, F., Lidén, M., Hintze, S. and Viking, K. (2013). Markvibrationer vid spontning för Karlstad teater. *Bygg & teknik*, Vol. 105, No. 1. (In Swedish)

Deckner, F. (2013). *Ground vibrations due to pile and sheet pile driving – influencing factors, predictions and measurements*. Division of Soil- and Rock Mechanics, KTH Royal Institute of Technology, Stockholm, Sweden, Licentiate Thesis 2019.

Guillemet, C. (2013). *Pile-Soil Interaction during Vibratory Sheet Pile Driving – a Full Scale Field Study*. Division of Soil- and Rock Mechanics, KTH Royal Institute of Technology, Stockholm, Sweden, Master of Science Thesis 13/05.

Deckner supervised the master thesis work.

Guillemet, C., Deckner, F., Viking, K. and Hintze, S. (2014). Nytt fältförsök visar en kraftigt minskad omgivningspåverkan närmast sponten. *Bygg & teknik*, Vol. 106, No. 1, pp. 25-30. (In Swedish)

Deckner, F., Larsson, T., Viking, K. and Hintze, S. (2016). Kunskap om spontbeteende vid vibrodrivning minskar skadekostnader. *Proceedings of Grundläggningdagen 2016*, 17 March, Stockholm, Sweden, pp. 107-118. (In Swedish)

Larsson, T. (2016). *Behavior of Vibrodriven Sheet Pile: A Numerical Analysis*. Department of Civil, Environmental and Natural Resources Engineering, Luleå University of Technology, Master of Science Thesis.

Deckner supervised the master thesis work.

TABLE OF CONTENTS

Preface.....	III
Summary	V
Sammanfattning	VII
List of notations	IX
List of publications.....	XI
Table of contents.....	XIII
1 Introduction	1
1.1 Background.....	1
1.2 Aim and objective.....	2
1.3 Extent and limitations.....	2
1.4 Method and outline.....	2
2 Vibration transfer process.....	5
2.1 Introduction	5
2.2 Description of process.....	5
2.3 Vibration source	6
2.4 Vibrations in soil.....	12
3 Field tests and instrumentation system	17
3.1 Introduction	17
3.2 Instrumentation system.....	18
3.3 Karlstad theatre	19
3.4 Solna tramway	22
3.5 Värta harbour.....	25
4 Numerical modelling.....	29
4.1 Introduction	29
4.2 Description of model.....	29
5 Summary of appended papers	33
5.1 Introduction	33
5.2 Paper I.....	33
5.3 Paper II.....	34
5.4 Paper III	34
5.5 Paper IV	35
5.6 Paper V.....	35
5.7 Paper VI	36
6 Discussion.....	37
6.1 Introduction	37
6.2 The ideal prediction model – how far from it are we?.....	37
6.3 Instrumentation system – future use and development?.....	39
6.4 Field tests – lessons and further development?	40
6.5 Numerical modelling – a future prediction model?	41
7 Conclusions and suggestions for further research	43
7.1 Introduction	43
7.2 Conclusions.....	43
7.3 Suggestions for further research	44
References.....	47

1 INTRODUCTION

1.1 BACKGROUND

The continued increase in demand for new housing and infrastructure in urban areas forces the construction industry to review current methods in order to minimise environmental impact. Two general trends in the modern construction industry are: building close to existing structures and building on land with poor ground conditions. This imposes a need for retaining walls as well as a great risk of disturbing nearby residents and causing damage to nearby objects. Today, vibratory sheet pile driving is the most cost-effective retaining wall method, mainly due to its relatively quick installation (NASSPA, 2009). In coming decades, the continued use of a cost-effective retaining wall method, such as vibratory driven sheet piles, is crucial for ensuring sustainable development of our urban areas.

It is known that vibratory sheet pile driving causes vibrations to spread: from the source to the ground and further to nearby objects (Clough & Chameau, 1980; Hintze, 1994; Athanasopoulos & Pelekis, 2000). These vibrations have the potential of disturbing people and causing damage to buildings or structures. Therefore, most urban construction projects face strict limits on the maximum permissible vibration level. When deciding which retaining wall type and installation method to use, the risk of exceeding this vibration limit is an important factor to consider. To be able to choose an appropriate retaining wall type and installation method from the point of view of both time and cost, as well as minimising the risk of disturbance, it is important to predict the likely vibration level prior to construction. This being the case, nowadays there is an increasing interest in being able to perform more reliable predictions to potentially optimise cost, minimise construction time and cause less damage and disturbance to the surroundings.

The prediction of vibration levels during pile and sheet pile driving has traditionally been based on empirical relationships, e.g. Attewell & Farmer (1973), developed for certain soil conditions and driving equipment. As the years pass they tend to be used as 'true' for many more conditions than those for which they were originally developed. Therefore, current predictions are usually far from reliable. Wrongful predictions are both costly and pose a risk of damage. The development of empirical relationships has not helped to increase general understanding of the fundamental mechanical behaviour involved in the vibration transfer process. Some research has been done on specific parts of the process (Kim & Lee, 2000 – propagation and attenuation of ground vibrations; Holeyman, 2002 – pile-soil-vibrator interaction; Auersch & Said, 2010 – attenuation of ground vibrations; Whenham & Holeyman, 2012 – vibrator-pile interaction), while others have studied the process as a whole (Heckman & Hagerty, 1978 – pile driving; Wiss (1981) – construction vibrations; Stille & Hall,

1995 – construction vibrations; Woods, 1997 – pile and sheet pile driving; Massarsch, 2004 – pile driving). Accurate characterisation of the vibration transfer process is necessary to improve ground vibration prediction.

1.2 AIM AND OBJECTIVE

The main aim of this doctoral thesis is to increase knowledge and understanding in the field of vibrations due to vibratory sheet pile driving. The thesis also aims to serve as a platform for the future development of a reliable prediction model for vibrations due to vibratory sheet pile driving.

The objective is to analyse the vibration transfer process, from source to soil during vibratory sheet pile driving, to emphasise important factors and parameters that need to be included in a reliable prediction model. The less exploited parts of the process are studied further to increase knowledge of the main contributing factors and the emergence of vibrations during vibratory sheet pile driving.

1.3 EXTENT AND LIMITATIONS

As can be deduced from the title, this thesis is focused on vibrations caused by vibratory sheet pile driving. However, in Papers I and II aspects of impact driven piles are also included. The term sheet pile refers to a u-shaped steel profile. Other types of profiles and materials are not included.

The analysis of the vibration transfer process during vibratory sheet pile driving is limited to the vibration source and the wave propagation in soil. Furthermore, ground vibrations are only discussed with respect to propagation in soil, not rock. Vibration transmission to nearby structures and the transfer of vibrations therein is not studied.

Parts of the work have been based on knowledge gained from field tests performed within the scope of this thesis. It is therefore natural that the content and conclusions are coloured by specific features of the field tests. The numerical model is limited to a single set-up. It also contains several assumptions and simplifications; however, these are accounted for in Section 4 and Paper VI.

1.4 METHOD AND OUTLINE

The methodology followed in this research project has been as follows. To increase knowledge and understanding in the field of vibration transfer during vibratory sheet pile driving, a joint research programme was started in 2009 by the construction company NCC, the Development Fund of the Swedish Construction Industry (SBUF) and KTH Royal Institute of Technology. First, a thorough literature study was conducted, giving an introduction to the field of research and the underlying theories, pointing out what is known and what further research needs to be done. After that, an initial field test was performed. The knowledge from the initial test was then used to develop a more sophisticated instrumentation system, which was used in two different field tests. Finally, based on

previous theories, experience from the field tests and new theory development, a numerical model was set up. The findings from the project have been presented in Papers I-VI (four journal papers and two peer-reviewed conference papers), as well as in one licentiate thesis, four popular scientific papers in Swedish and three master theses. Figure 1.1 illustrates how the work presented in Papers I-VI is linked together, using a sketch of the vibration transfer process during vibratory sheet pile driving.

This thesis is written as a compilation thesis and consists of an introductory part and six appended peer-reviewed papers. The introductory part ('Kappan') consists of seven chapters and is a complement to the appended papers as well as providing a wider context to the problem. The outline of the introductory part is as follows:

- **Chapter 1** contains background to the research project as well as the aim and objective. The extent and limitations of the study are specified and the method is described.
- **Chapter 2** describes the vibration transfer process during vibratory sheet pile driving, from source to soil.
- **Chapter 3** summarises the three field tests that have formed a platform for the research project.
- **Chapter 4** provides a brief description of the numerical model that was developed to study sheet pile behaviour.
- **Chapter 5** comprises a summary of the appended papers.
- **Chapter 6** discusses the future development of a prediction model and suggestions for future use of the instrumentation system that was developed.
- **Chapter 7** closes the thesis by listing its conclusions; suggestions for further research are also included in this chapter.

The papers appended to this thesis are all linked together, as can be seen in Figure 1.1. A short description of the papers follows, explaining how they are inter-connected, and there is a longer summary of each paper in Chapter 5.

In **Paper I** existing prediction models are discussed and investigated. The models are divided into groups depending on their nature, and the pros and cons of the existing prediction models are listed. The study led to the conclusion that the criteria for an ideal prediction model are that it should be easy for a practising geotechnical engineer to use, and the necessary input data should be readily attainable. The study in Paper I also showed that none of the existing prediction models fulfil the above criteria.

To develop a new prediction model, it is important to have good knowledge of the vibration transfer process from source to a point of interest in the soil. In **Paper II** different factors influencing the transfer of vibrations are identified and discussed. The conclusion is that there are factors that need further study and these should be included in a new prediction model, namely the vibrations transferred from sheet pile to soil, geotechnical conditions, and distance from the source.

To study the transfer of vibrations from sheet pile to soil further, a new instrumentation system was developed and a field test conducted. **Paper III** gives a detailed description of the instrumentation system and the field test. In Paper III and **Paper IV** the vibration transfer

from sheet pile to soil is studied from different angles. In Paper III it is suggested that in the above-mentioned field test the toe contributes more to the vibrations in the ground than the shaft. Paper IV presents a new model for vibration transfer and the different waves generated during vibratory sheet pile driving.

Paper V focuses on the wave patterns that arise in the soil during vibratory sheet pile driving. The main conclusions are that Rayleigh waves develop at the surface in close proximity to a driven sheet pile, while at depth in the ground the patterns are more irregular. It was also observed that as the distance from the source increased, so did the irregularity of the wave patterns.

In **Paper VI** focus is placed on the source, namely on the behaviour of the sheet pile during driving. A numerical analysis is performed, imitating the field test described in Paper III, and it is concluded that during vibratory driving with eccentric clamping the sheet pile bends in a horizontal direction.

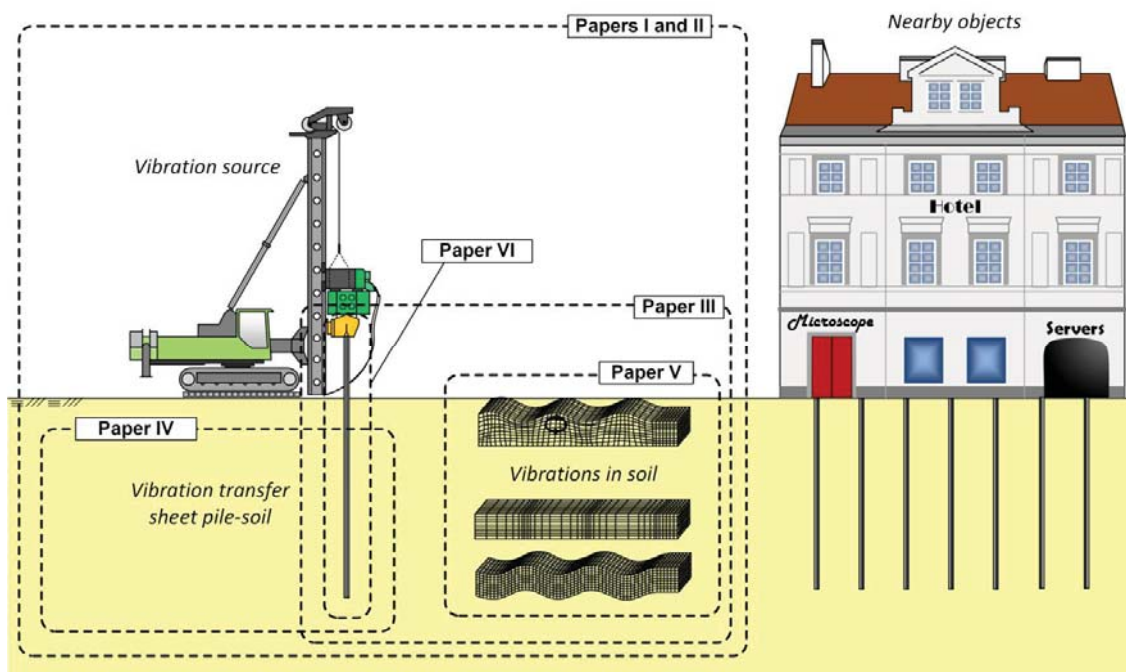

Figure 1.1 Illustration of connection between the works performed within the scope of the current research.

2 VIBRATION TRANSFER PROCESS

2.1 INTRODUCTION

During vibratory sheet pile driving vibrations are transferred from the source to nearby objects, which are susceptible to damage. An important aspect of creating more reliable prediction is to reduce uncertainty. One cause of uncertainty is ignorance, i.e. what is known as epistemic uncertainty (Walker et al., 2013). Thus, gaining knowledge of the vibration transfer process leads to uncertainty being reduced.

In this chapter the vibration transfer process during vibratory driving is presented and the different parts of the process covered in this research project are further explained.

2.2 DESCRIPTION OF PROCESS

The vibration transfer process is the transfer of vibrations from the source to nearby objects via media able to transfer vibrations (see e.g. Massarsch, 2004). The source in this case is the vibrator used to set the sheet pile into motion in order to enable penetration into the ground. ‘Nearby objects’ is used as a generic term here to describe buildings or other structures, equipment and people that may be affected by the vibrations on a scale ranging from damage to nuisance. The media is the material transporting vibrations from source to nearby objects. In this thesis media is limited to soil materials.

The vibration transfer process is herein schematically divided into the following parts (see Figure 2.1):

1. Vibration source
 - a. Vibratory driving equipment (other types of driving are not discussed)
 - b. Sheet pile behaviour
 - c. Vibration transfer from sheet pile to soil
2. Vibrations in soil
3. Nearby objects

In this thesis *vibration source* and its sub-categories as well as *vibrations in soil* are described. The *nearby objects* part, which also includes vibration transfer between soil and foundation, vibration transmission within the structure, etc., is not included; instead the reader is referred to the following publications for reviews of vibrations in nearby structures and damage thereto: Holmberg et al. (1984), Head & Jardine (1992), Hintze (1994), Niederwanger (1999) and Svinkin (2008).

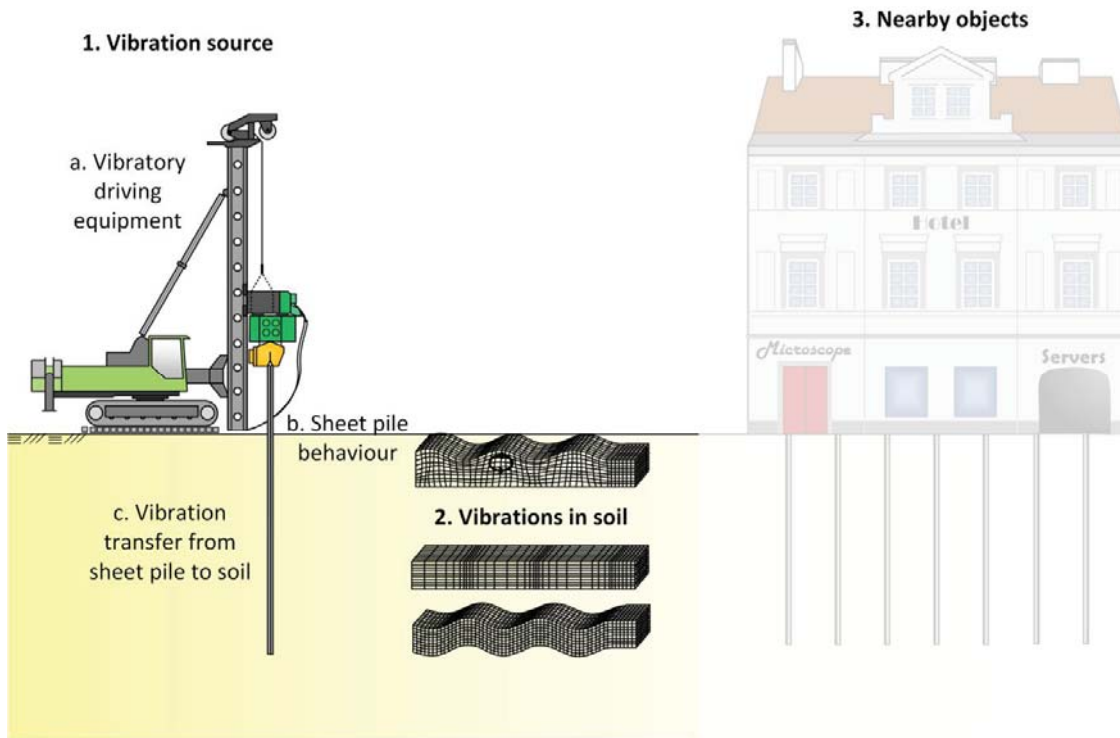

Figure 2.1 Schematic illustration of the vibration transfer process during vibratory sheet pile driving.

2.3 VIBRATION SOURCE

2.3.1 Vibratory driving equipment

Previous studies by e.g. Viking (2002) have covered the method of vibratory driving and driveability. Here a brief description of vibratory driving is presented, with the focus on explaining the characteristics of the driving process, which affect the vibration transfer.

During vibratory sheet pile driving a vibrator is attached to the top of the sheet pile, setting it into vibratory motion, to enable penetration into the ground (see Figure 2.2). Apart from the vibratory motion induced by the vibrator, a stationary action caused by the weight of the vibrator and sheet pile pushes the sheet pile into the ground (Holeyman, 2002).

An even number of eccentric masses rotate within the vibrator to induce the vibration. The masses are placed opposite one another and rotate in opposite directions, so the horizontal component is cancelled out and only the vertical component remains (see Figure 2.3) (Woods, 1997).

The clamp holding the sheet pile usually has two claws placed on either side of the sheet pile web (eccentric clamping) and these are pushed together using hydraulics. There are clamps equipped with a double set of claws holding the sheet pile in the flanges instead (concentric clamping); however, these are rarely used (Viking, 2002; Whenham, 2011). The clamping holds the sheet pile firmly and in most cases the losses between clamp and sheet pile can be considered negligible (Westerberg et al., 1995).



Figure 2.2 Driving of sheet piles using a vibrator attached to the top of the sheet pile web.

The vibrating force exerted by the vibrator depends on the weight of the eccentric masses, the moment of the eccentric masses and the driving frequency (see Figure 2.3). How large the losses are between the vibrator and the sheet pile has been briefly touched upon by Holeyman (2002), Viking (2006) and Whenham & Holeyman (2012), but further research is needed here. A general approach is to use a percentage of the vibrator force that is transferred on, even though it is deemed too crude an approach by Athanasopoulos & Pelekis (2000).

During each cycle a significant mass is moved up and down. This is usually referred to as the vibrating mass and it consists of the weight of the moving part of the vibrator, the clamp and the sheet pile itself. This mass is rather significant as it exerts a moment of inertia for each cycle.

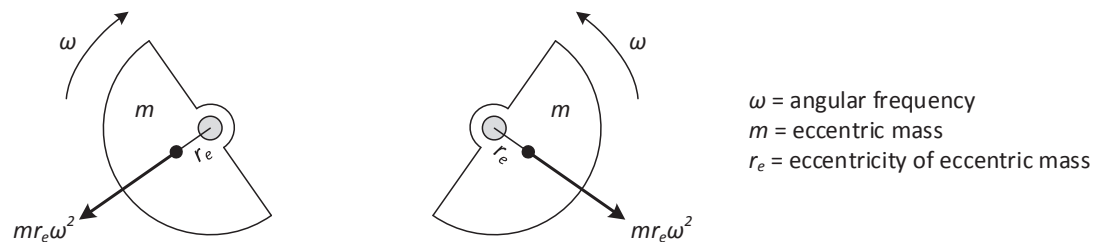

Figure 2.3 Schematic illustration of rotating masses in the vibrator and the accompanying force vectors.

2.3.2 Sheet pile behaviour

Vibration records from field tests performed within the scope of this thesis (see Paper III and IV), as well as previous research (Viking, 2002; Whenham, 2011) show that during vibratory driving there is excessive movement of the sheet pile in both vertical and horizontal directions. Sheet pile behaviour during driving, both singularly and in interlock, is mainly controlled by sheet pile geometry, loading conditions and driving frequency.

Sheet piles are geometrically slender structures with a cross-sectional area that is small in relation to its length. In this thesis, only u-shaped steel profiles are studied. A typical sheet pile cross section is displayed in Figure 2.4. In the figure the neutral layer of the sheet pile is portrayed, as well as where the clamp is usually placed during driving with eccentric clamping.

The usual loading condition for a vibratory driven sheet pile is that the clamp holds the sheet pile in the web (see Figure 2.2), adding both the vibratory load and the static load eccentrically. As a combination of the sheet pile geometry and the loading conditions, the sheet pile will bend during driving, as shown in Paper VI. However, it is not only the eccentric placement of the load that gives rise to bending. Due to their manufacturing and slenderness, it is assumed that no piles or sheet piles are perfectly straight but that all have a small initial deflection. This initial deflection would also cause the sheet pile to bend when load is applied to its top. The vibratory driving also gives rise to wave propagation within the sheet pile, which could also enhance the bending.

Depending on their geometry, all sheet pile profiles have eigenfrequencies for bending; hence, if the sheet pile profile is excited by a frequency close to one of its eigenfrequencies, bending will be enhanced. In Paper VI it was calculated that the eigenfrequency of the sheet pile profile was close to the driving frequency (i.e. the excitation frequency) in the Solna tramway field test (see Section 3.4). In the paper, it was shown that the bending mode clearly resembled what would be expected with the corresponding frequency. Hence, it is likely that the bending is related to the driving frequency, something which is also supported by Borel et al. (2002). However, further research is needed to confirm this conclusion.

Principally, sheet piles are driven singularly (a) or in interlock (b) (see Figure 2.5). During driving, vibrations are also transferred to adjoining sheet piles (c), causing motion of the sheet pile wall; this is discussed further in Paper IV. It is likely that the behaviour of the sheet pile would be affected by whether it is driven singularly or in interlock, since the lock prescribes motion along one side of the profile. However, field test results from the Solna tramway field test (see Section 3.4) do not show any difference in sheet pile behaviour between sheet piles driven singularly or in interlock, whereas previous studies by Viking (2006) have shown larger ground vibration amplitudes when sheet piles are driven in interlock compared to when singularly driven. More research is therefore needed to clarify the effect of driving in interlock.

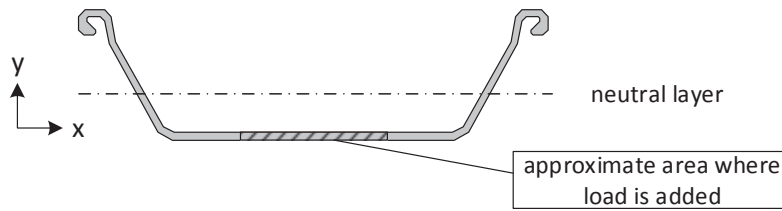

Figure 2.4 Common u-shaped sheet pile geometry seen from above. The profile's neutral layer and area where load is added are highlighted.

2.3.3 Vibration transfer from sheet pile to soil

As the sheet pile penetrates the ground, vibrations are transferred from the sheet pile shaft as well as from the toe into the surrounding soil. However, the vibration amplitude of the sheet pile is not directly transferred to the same vibration amplitude in soil. Results from the Solna tramway field test (presented in Guillemet (2013)) showed that the vibration amplitude is reduced by approximately 99 % when going from sheet pile to a point in the ground ~0.35 m from the sheet pile profile.

The main reason for this loss is slippage between sheet pile shaft and soil while driving, along with high strain. Both shear modulus, G , and damping ratio, ζ , are dependent on strain level (Vucetic & Dobry, 1991). Hence, in the zone closest to the sheet pile the soil is – to a large extent – unable to transfer vibrations. Figure 2.6 illustrates the sheet pile shaft, the slippage and how the shear modulus increases and the damping ratio decreases as the distance from the sheet pile increases. This is modelled and discussed further in Paper VI.

Slippage is a term used for when the sheet pile and soil lose direct contact, i.e. the sheet pile moves relative to the soil right next to the shaft. The effect of slippage can be illustrated using a hysteresis loop (see Figure 2.8). The hysteresis loop shows cyclic shear strain, γ , and shear stress, τ , in a closed curve for one vibration cycle. The area within the curve represents the energy dissipated in each cycle (Voznesensky & Nordal, 1999), and from the dissipated energy the hysteretic damping ratio, ζ , can be calculated. The maximum shear modulus, G_{max} , the equivalent shear modulus, G_{equ} , and the equivalent shear modulus with respect to slippage, $G_{equ_slippage}$, can be derived from the response of the soil displayed in the hysteresis loop.

At the toe the mechanisms are somewhat different. Each cycle involves the sheet pile being lifted, losing contact with the soil at the toe and then being pushed downwards, hitting and penetrating the soil (see Figure 2.7) (Feng & Deschamps, 2000; Viking, 2002). During downward motion, there is an impression on the soil and it displaces downwards. This induces large strains below the toe, and just as along the shaft, the shear modulus is reduced and damping increased in proximity to the sheet pile toe. The zone of high strain below the toe is likely to be bulb-shaped (see Figure 2.9). This shape is based on numerical calculations performed using the model presented in Section 4 and previous research by Sheng et al. (2005).

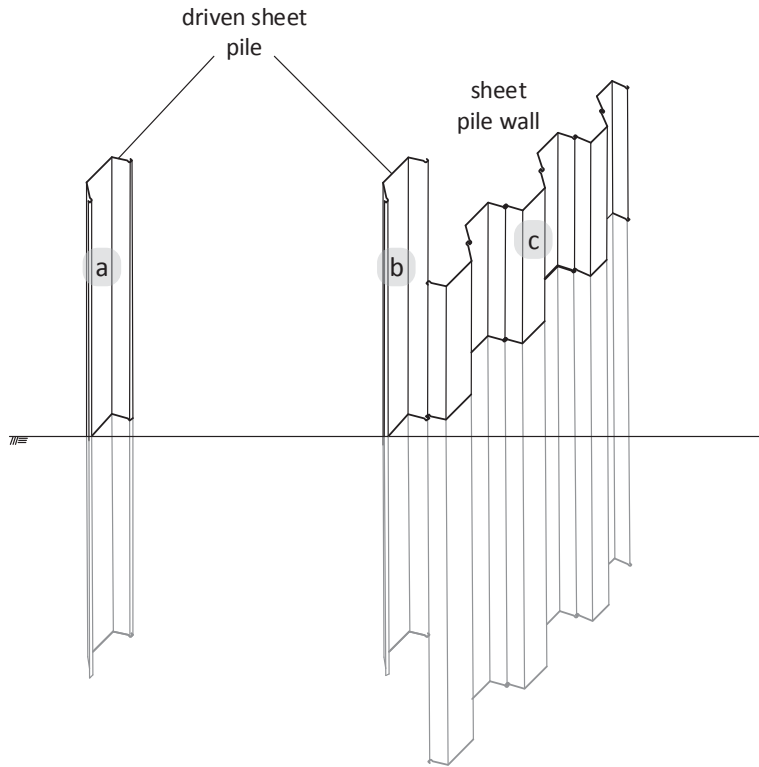

Figure 2.5 Different stages of sheet pile driving: a) driving of single sheet pile, b) driving of sheet pile in interlock, and c) sheet pile wall that has already been installed.

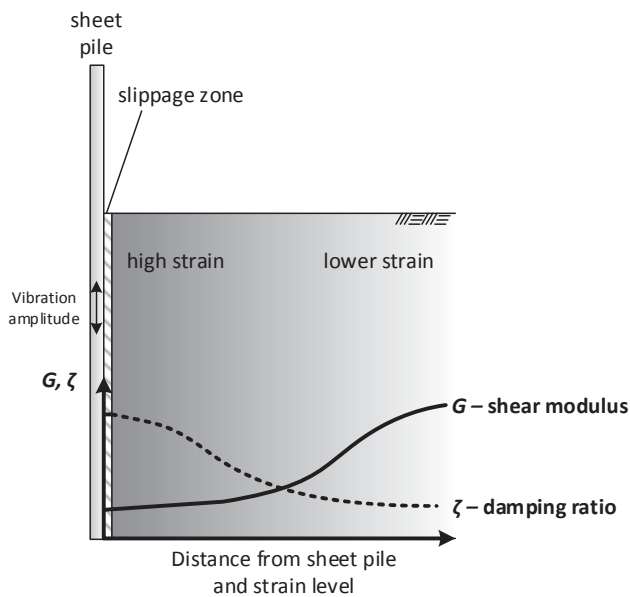

Figure 2.6 Schematic illustration of slippage and variation of strain in close proximity to a sheet pile shaft. The development of G and ζ with the distance from the driven sheet pile is also portrayed.

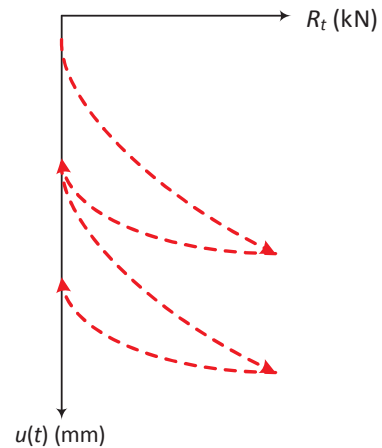

Figure 2.7 Schematic illustration of variation of sheet pile toe resistance (R_t) with vertical displacement ($u(t)$), after Viking (2002).

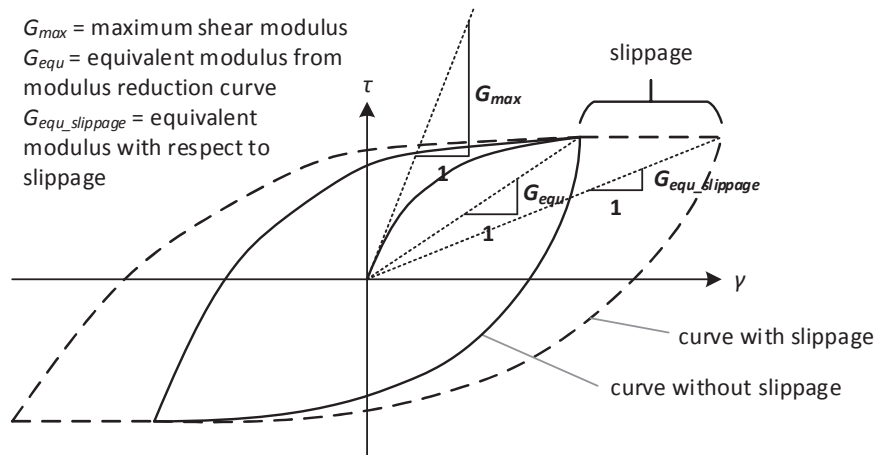

Figure 2.8 Hysteresis loop illustrating soil behaviour during one cycle, where τ is shear stress and γ is shear strain.

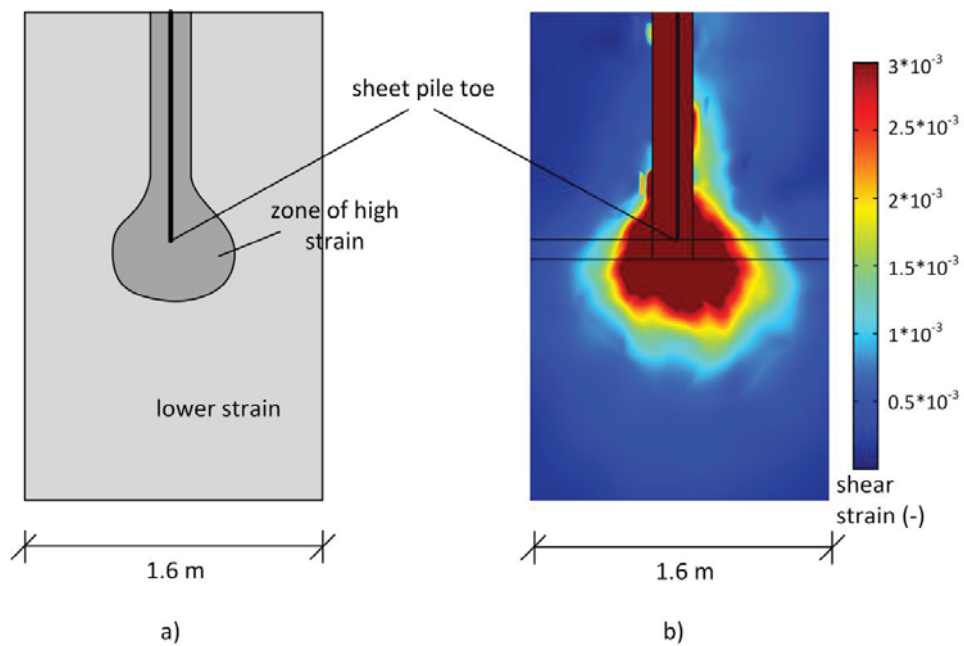

Figure 2.9 Illustration of large strain "bulb" beneath sheet pile toe during driving; a) schematic illustration, b) result from numerical calculation with model presented in Section 4 and Paper VI.

2.4 VIBRATIONS IN SOIL

The main existing theory for the transfer of vibrations from piles to soil is based upon the work of Attewell & Farmer (1973), which has been successively developed over the years to apply to both impact driven piles and vibratory driven sheet piles. The existing vibration transfer model is presented in Figure 2.10. From the toe, P- and S-waves emanate in spherical wave fronts and from the shaft S-waves emanate in cylindrical wave fronts. This model has been developed for impact driven piles assumed to move solely in the vertical direction during driving. This is not the case for vibratory driven sheet piles; as was shown in the previous section, the sheet pile moves considerably in the horizontal direction as well. Therefore, it is suggested that the model is developed further and that a P-wave front emanating from the shaft is added to account for the horizontal motion of the sheet pile during driving (see Figure 2.11 and Paper IV). This is supported by measurements during impact pile driving as well, presented by Ramshaw et al. (2000). They noticed the occurrence of a P-wave from the pile shaft, probably occurring due to an eccentric strike.

From the study of wave patterns in the ground during sheet pile driving (see Paper V), the results from when the sheet pile toe is in the clay layer comply well with the theory developed for vibration transfer (see Figure 2.12). Both P- and S-waves emanate from the toe, affecting the wave pattern in sensor MP2-2. The point below the sheet pile toe, MP2-3, is mainly affected by P-waves from the toe. From the shaft, there are mainly S-waves affecting the wave pattern in MP2-1. However, the slight inclination indicates the presence of P-waves as well. The study in Paper V is limited to when the sheet pile toe is in a clay or loose sand layer. Results from the Karlstad theatre field test (see Section 3.3) indicate a higher horizontal vibration level in the ground when the toe penetrates a stiffer soil layer. Hence, it is likely that the particle displacement path along the shaft (MP2-2 in Figure 2.12) would have a larger contribution from horizontal vibration components, and thus a more oval shape, when the toe reaches a stiffer soil layer.

As the waves reach the ground surface, surface waves – mainly Rayleigh waves – develop. For a long time it was not known how close to a pile or sheet pile clear wave patterns developed and it has also been claimed that true wave propagation is not observed within the short distances that are usually of concern for vibration problems due to sheet pile driving (Attewell & Farmer, 1973; Head & Jardine, 1992). Field tests within the scope of this study (see Paper V), as well as previous studies (Athanasopoulos & Pelekis, 2000; Whenham, 2011), show that Rayleigh waves develop very close to a driven pile; at about ~0.5 m a clear Rayleigh wave pattern can be distinguished.

Usually, the ground into which sheet piles are driven consists of different materials in different layers. This gives rise to reflections and refractions as waves hit boundaries between layers with different properties. Numerous researchers have pointed out the considerable effect layering in the ground can have on the wave propagation in soil (see e.g. Athanasopoulos-Zekkos et al., 2013; Kouroussis et al., 2013). To make the wave pattern in the soil even more complex there are usually – at least in urban areas – objects in the ground, such as tunnels, foundations, pipes, etc. These objects also make the waves reflect and refract, creating immensely complex wave patterns in the ground. Möller et al. (2000) pointed out the fact that, due to the combination of refraction, reflection and interference of

waves, wave patterns in layered materials are very hard to foresee theoretically. Masoumi et al. (2006) performed numerical calculations and experienced interference from reflected waves at the ground surface in a layered soil profile.

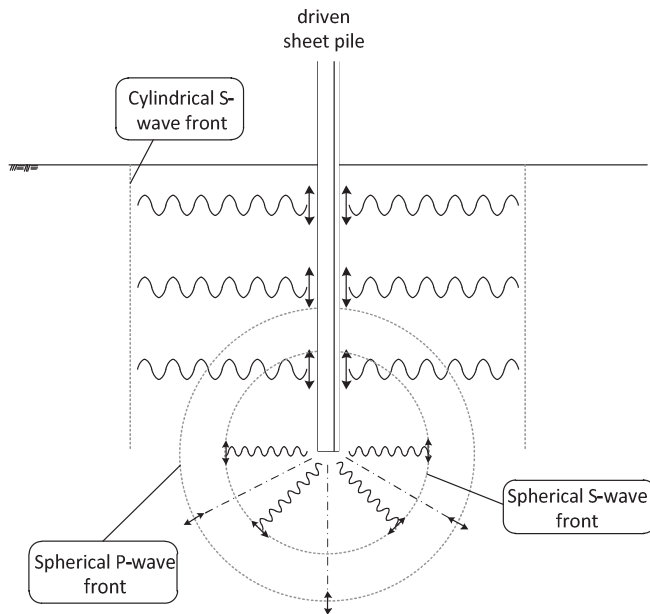

Figure 2.10 Existing vibration transfer model during vibratory sheet pile driving, originating from Attewell & Farmer (1973).

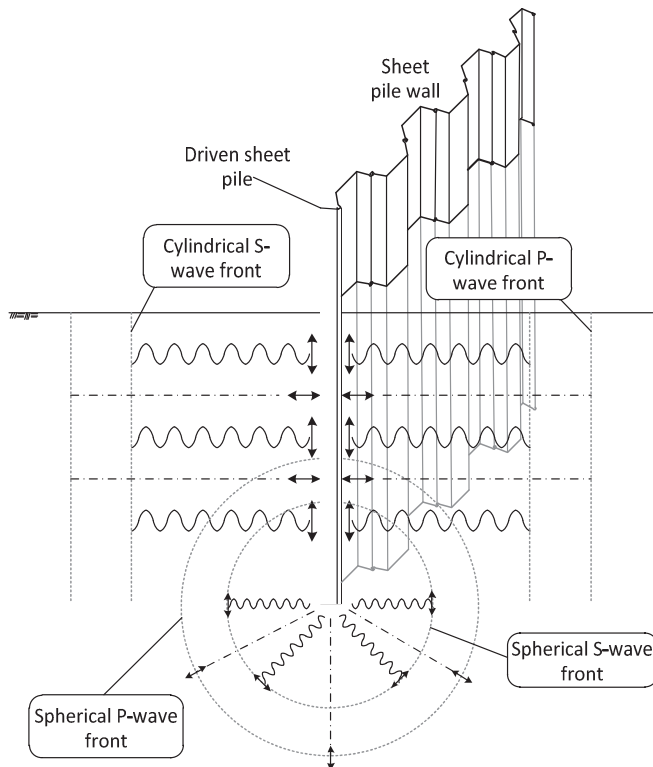

Figure 2.11 Vibration transfer model during sheet pile driving, as developed, from Paper IV.

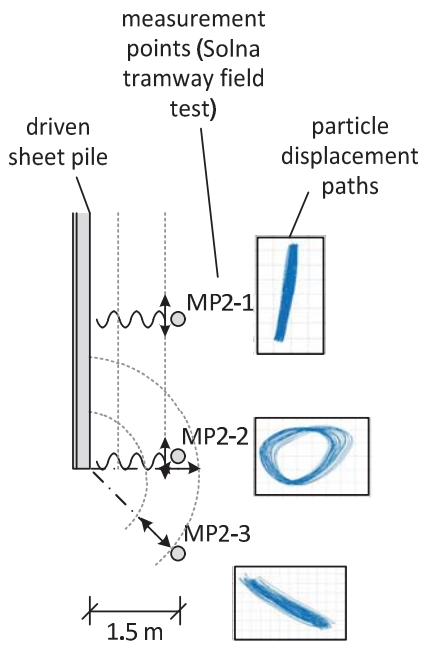

Figure 2.12 Particle displacement paths recorded at sheet pile toe depth 4.7 m in measurement points MP2-1, MP2-2 and MP2-3, which were buried in the ground at depths 2.7 m, 4.7 m and 6.2 m, respectively.

Sheet piles are most often driven into interlock with another profile in order to create a retaining wall (see Figure 2.5). This means that, during driving in interlock, vibrations are transferred both to the soil and to the adjoining sheet pile wall. The Solna tramway field test showed that vibrations are transferred to adjoining sheet pile profiles (see Paper IV). The field test results give no indication that this vibration transfer leads to higher vibration levels in the ground. However, they did indicate that when sheet piles are driven in interlock the vibration pattern in the ground becomes more disorderly than when a single sheet pile is driven (see Paper V).

The distance from the source is an important parameter when it comes to ground vibration level (see discussion in Paper II). If no resonance occurs in the soil, vibrations attenuate relatively fast with increasing distance from the source due to geometric damping and material damping. However, if resonance were to occur, a whole soil layer could potentially be set in motion and vibrations could spread with high amplitude over large distances (see e.g. Erlingsson & Bodare, 1992 and 1996).

Geometric damping reduces vibration amplitude by the distance from the source due to the spread of energy over an increasingly large surface or volume. Material damping reduces vibration amplitude by the transfer of vibration energy to friction heat between particles as the wave propagates. Hysteretic damping is a good measure of material damping, promoted by e.g. Kouroussis et al. (2013). It is a measure of energy lost per cycle (see Figure 2.8) and is dependent of shear strain.

The total attenuation of waves propagating in soil is usually approximated by the following relationship:

$$A_2 = A_1 \left(\frac{r_1}{r_2} \right)^n e^{-\alpha(r_2-r_1)} \quad \text{Eq. 2.1}$$

where A_1 is vibration amplitude at distance r_1 from the source, A_2 is vibration amplitude at distance r_2 from the source, α is an absorption coefficient and n is $\frac{1}{2}$ for surface waves, 1 for body waves and 2 for body waves along the surface.

As attenuation relationships are dependent on the wave present (see Eq. 2.1), it is important to have knowledge of the waves present in the ground. To study the wave pattern in the ground due to vibratory driven sheet piles, data from three field tests was used (see Paper V). One of the field tests contained data from in-depth sensors while the other two contained data from surface sensors. The data was compared and analysed, and it confirms the common theory that Rayleigh waves are present at the ground surface and at depth in the ground there is a combination of P- and S-waves instead. It was also shown that the wave patterns become more disorderly as the distance from the sheet pile increases, which is probably due to reflection and refraction of waves. When these reflected and refracted waves come together at certain points, a magnification of vibration levels can be seen. For example, this can be seen in numerical calculations by Masoumi et al. (2006) and in the Karlstad theatre field test (see Section 3.3). The study is explained in more detail in Paper V, where some additional data has been included.

3 FIELD TESTS AND INSTRUMENTATION SYSTEM

3.1 INTRODUCTION

Within the scope of this research project three field tests have been performed (Karlstad theatre, Solna tramway and Värta harbour) and an instrumentation system was developed for recording vibrations during vibratory sheet pile driving. This chapter includes an introduction to the instrumentation system along with a brief description of each field test. Some of the primary results from each field test are also presented.

To facilitate comparison between the three field tests Table 3.1 has been compiled, containing the main distinguishing features of the different field tests.

Table 3.1 Main distinguishing features of the three field tests.

Field test	Karlstad theatre	Solna tramway	Värta harbour
Geotechnical conditions	fill – sand (silt) – clay	fill – clay – moraine – bedrock	fill – clay – moraine – bedrock
Sheet pile type	PU12	Larssen 603	Larssen 604
Sheet pile length	12 m	13.8 m and 11 m	12 m
Vibrator	Dieseko 2316VM	Liebherr 1100H	ABI TM 14/17V
Driving frequency	28 Hz	35 Hz	36 Hz
Sensor type	Triaxial and uniaxial geophones	Triaxial accelerometers	Triaxial accelerometers
No. of sensors on sheet piles	0	9	1
No. of sensors at depth in ground	0	9	0
No. of sensors on ground surface	3	0	3
Included in Paper no.	V	III, IV, V and VI	V
Use of new instrumentation system	No	Yes	Yes

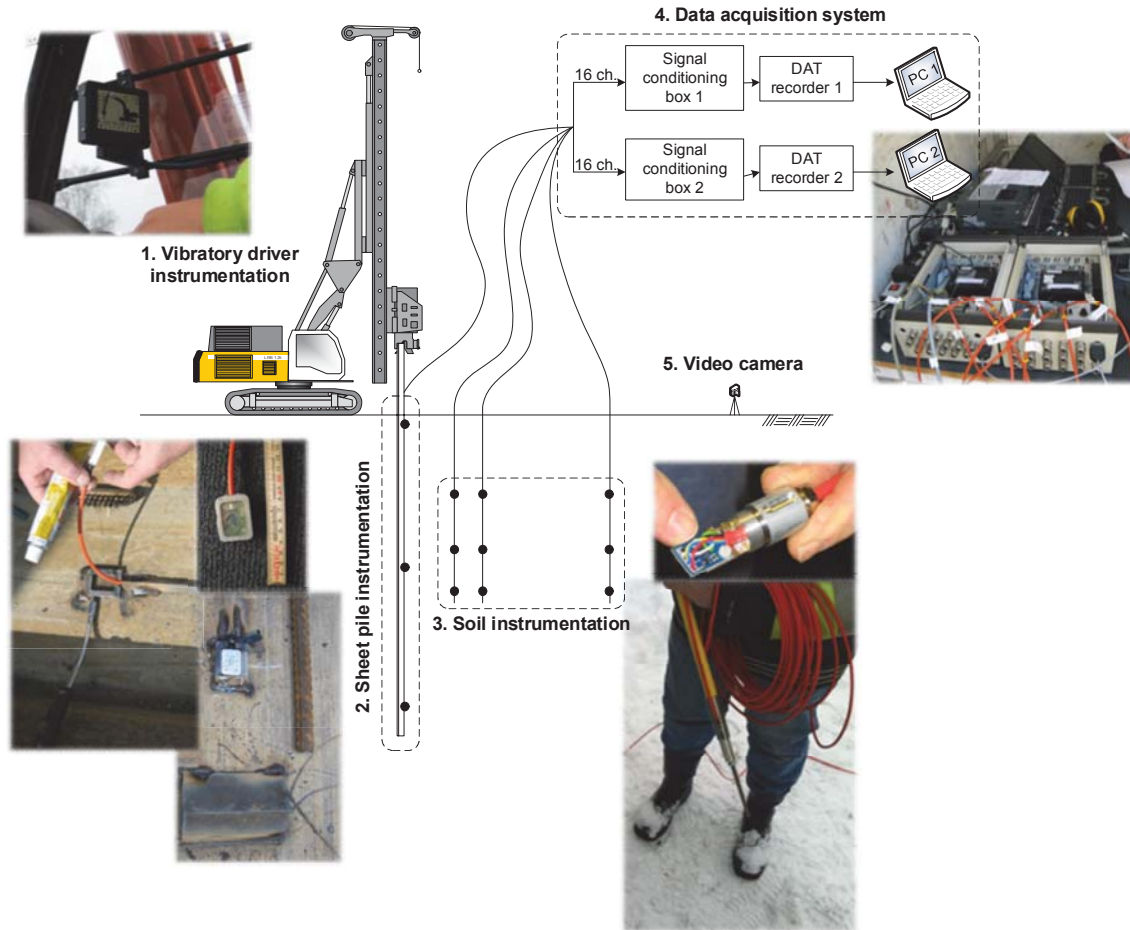

Figure 3.1 Schematic illustration of instrumentation system, including photos of parts of the equipment.

3.2 INSTRUMENTATION SYSTEM

A new instrumentation system was developed to enable the recording of sheet pile and ground vibrations and facilitate data acquisition from different sources. The system was developed with the help of Kent Allard and Kent Lindgren. A detailed description of the instrumentation system is presented in Paper III. In this section a brief description of the system is provided.

The instrumentation system is divided into five parts (see Figure 3.1):

1. **Vibratory driver instrumentation** – The Liebherr piling rig’s own logging system is used to record parameters associated with the driving equipment, such as penetration depth, vibration frequency and amplitude.
2. **Sheet pile instrumentation** – Triaxial microelectromechanical system (MEMS) capacitive accelerometers are used to record sheet pile accelerations. The sensors are mounted into protective steel casings welded onto the sheet pile.

3. **Soil instrumentation** – Triaxial MEMS capacitive accelerometers are used to record ground vibrations. The accelerometers are fitted into protective steel cylinders, which are pressed into the soil using specially-constructed fibre glass rods.
4. **Data acquisition system** – Two separate chains working in parallel record the signals. Each chain contains a signal conditioning box, a digital audio tape (DAT) recorder and a laptop computer (PC), giving a capacity of 32 recording channels.
5. **Video camera** – A water- and dust-proof video camera is placed on a tripod for visual documentation of the driving.

Processing of the data is performed in MATLAB® software.

3.3 KARLSTAD THEATRE

3.3.1 Introduction

The first field test in this research project was performed in May 2010. It was conducted in Karlstad, Sweden, where the old building of Karlstad theatre was to be extended. For the specific location of Karlstad theatre and the test site layout see Figure 3.2. The main aim of the field test was to monitor vibrations during a trial vibratory sheet pile driving exercise to determine whether the method was suitable for the prevailing conditions. More information regarding the field test can be found in Lidén (2013).

3.3.2 Measurement procedure

The theatre and surrounding buildings are founded on loose geological deposits close to the Klarälven river delta (see Figure 3.2). The natural soil, beneath a 1.2 m fill layer, consists of loose, fine-grained river sediments, mainly sand with elements of silt. Underneath the sand a clay layer continues to a depth of at least 25 m. The groundwater level was measured to approximately 3 m below the original ground surface. In Figure 3.3 a characteristic soil profile is presented.

The driven sheet piles were of type PU12 and 12 m in length. The vibrator used to drive the sheet piles was a Dieseko 2316VM. The vibrator itself is a free-hanging model, but was in this case mounted on a leader (see Figure 3.4).

Four sheet piles were driven to a depth of 10.5-11 m during the trial sheet piling and measurements were taken during the driving of the last three (see Figure 3.2). First, a single sheet pile was driven; thereafter sheet piles S1, S2 and S3 were driven in that order, meaning that all measurements correspond to driving the sheet pile into interlock with another profile. Geophones were positioned at three separate locations: MP1, MP2 and MP3, at distances of 3.4 m, 7.9 m and 15 m from the sheet pile line, respectively (see Figure 3.2).

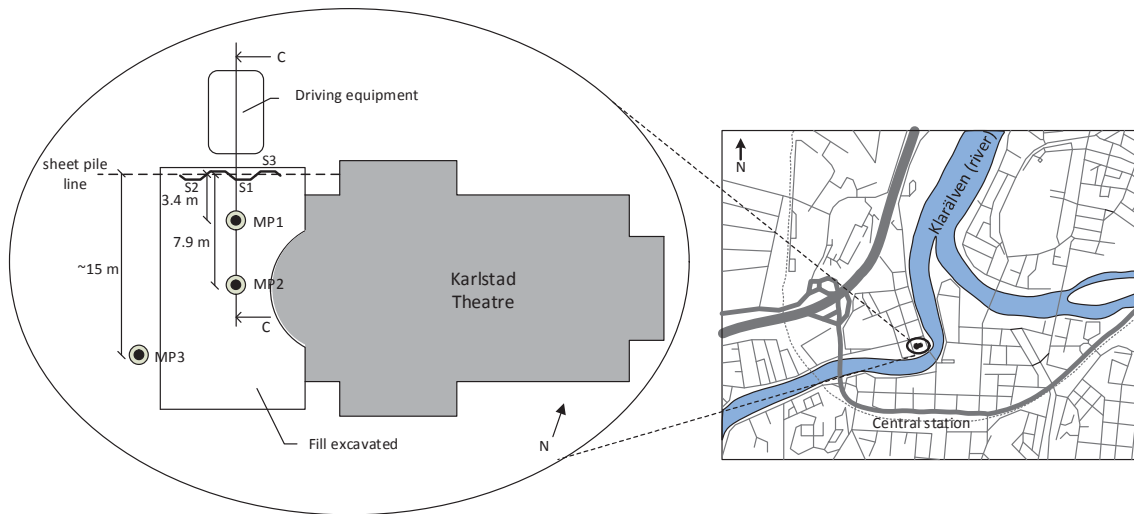

Figure 3.2 Location of the Karlstad theatre field test within the city of Karlstad as well as a plan view of the test site.

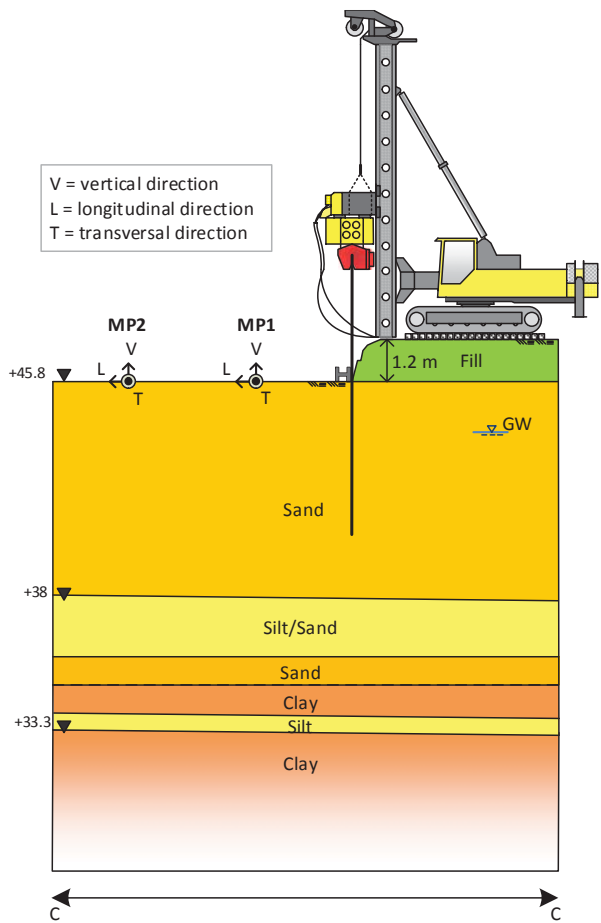

Figure 3.3 Characteristic soil profile for the Karlstad theatre field test site. Location of MP1 and MP2 are also visible.



Figure 3.4 Photo of driving equipment used in the Karlstad theatre field test.



Figure 3.5 Photo of triaxial geophone (foreground) and the recording device (background) from the Karlstad theatre field test.

Two triaxial geophones (MP1 and MP2) and one uniaxial geophone (MP3) were used. The triaxial geophones were connected to a recorder (see Figure 3.5), which was able to record an event at a sampling rate of 750 Hz for a limited time period of 70 s up to a maximum amplitude of 27 mm/s. However, the driving of a single sheet pile lasted for a longer period than 70 s, so the entire driving process was not registered. The uniaxial geophone was connected to equipment that recorded only maximum values. The measurement and recording equipment was supplied by Bergsäker AB.

To register penetration depth and driving velocity of the sheet pile, chalk markings were placed every 0.1 m on the sheet pile. A video camera was placed about 10 m from the sheet pile line to film the entire driving process.

3.3.3 Main results

A brief summary follows of the main results from the Karlstad theatre field test.

The recorded vibrations attenuate with distance from the source. However, it is noteworthy that the attenuation is not always linearly dependent on the distance. The results indicate that there seems to be a distance at about 10 m from the source where the vertical vibrations reach a maximum value before they begin to decrease in magnitude as distance increases. This had previously been observed in several other studies (e.g. Selby, 1991; Head and Jardine, 1992; Jongmans, 1996; Athanasopoulos and Pelekis, 2000).

A study of the vibration level in connection with toe penetration depth has shown that the geotechnical conditions influenced the ground vibration magnitude to a considerable extent.

However, the horizontal vibrations seem to be affected to a greater extent than the vertical vibrations. Similar results were also noticed by Martin (1980) for measurements of ground vibrations during impact driving of sheet piles.

More information and results from this field test are presented in Lidén (2013) and Paper V.

3.4 SOLNA TRAMWAY

3.4.1 Introduction

To facilitate transport between the western and northern parts of Stockholm, the existing tramway from Sickla to Alvik was extended from Alvik to Solna. For the section past Solna Centrum the contractor NCC and the foundation subcontractor Hercules had to construct a concrete structure leading to a tunnel below the Frösundaleden road. In order to safely construct the concrete structure a sheet pile wall was needed. The location of the field test site and the location of the sheet pile wall within the test site are shown in Figure 3.6.

This second field test was done purely for research purposes and Hercules allowed two days of work in May 2013 when measurements could be performed at the construction site. The sheet pile wall driven in the field test was removed and was never used in the final construction. The aim of the field test was to obtain data to enable a detailed study to be done of the sheet pile-soil interface during driving, using the new instrumentation system.

3.4.2 Measurement procedure

The geotechnical conditions at the field test site are common for the Stockholm area. A layer of fill of unknown origin is resting upon a clay layer, which overlays moraine on bedrock. A characteristic soil profile is shown in Figure 3.7a.

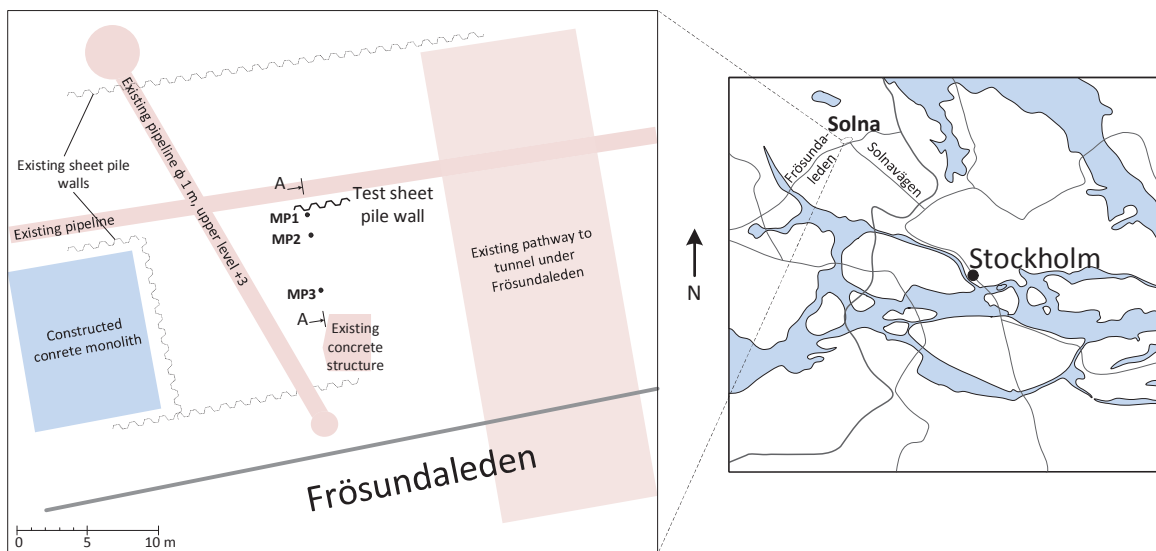

Figure 3.6 Location of the Solna tramway field test in relation to Stockholm city as well as a plan view of the test site.

Larsen 603 sheet piles were used and they were driven by a Liebherr 1100H vibrator using a frequency of 35 Hz (see Figure 3.8). The sheet piles were driven to a stop in the moraine layer.

To capture vibrations of both the driven sheet piles and the soil, sensors were positioned at three levels on the sheet pile profiles and at nine locations in the soil (see Figure 3.7). In total, seven sheet pile profiles were driven and vibrations were recorded both on driven sheet piles, on sheet piles that were already installed, and in the ground. The measurement equipment used is described in Section 3.2.

For a more detailed description of the field test the reader is referred to Paper III and Guillemet (2013).

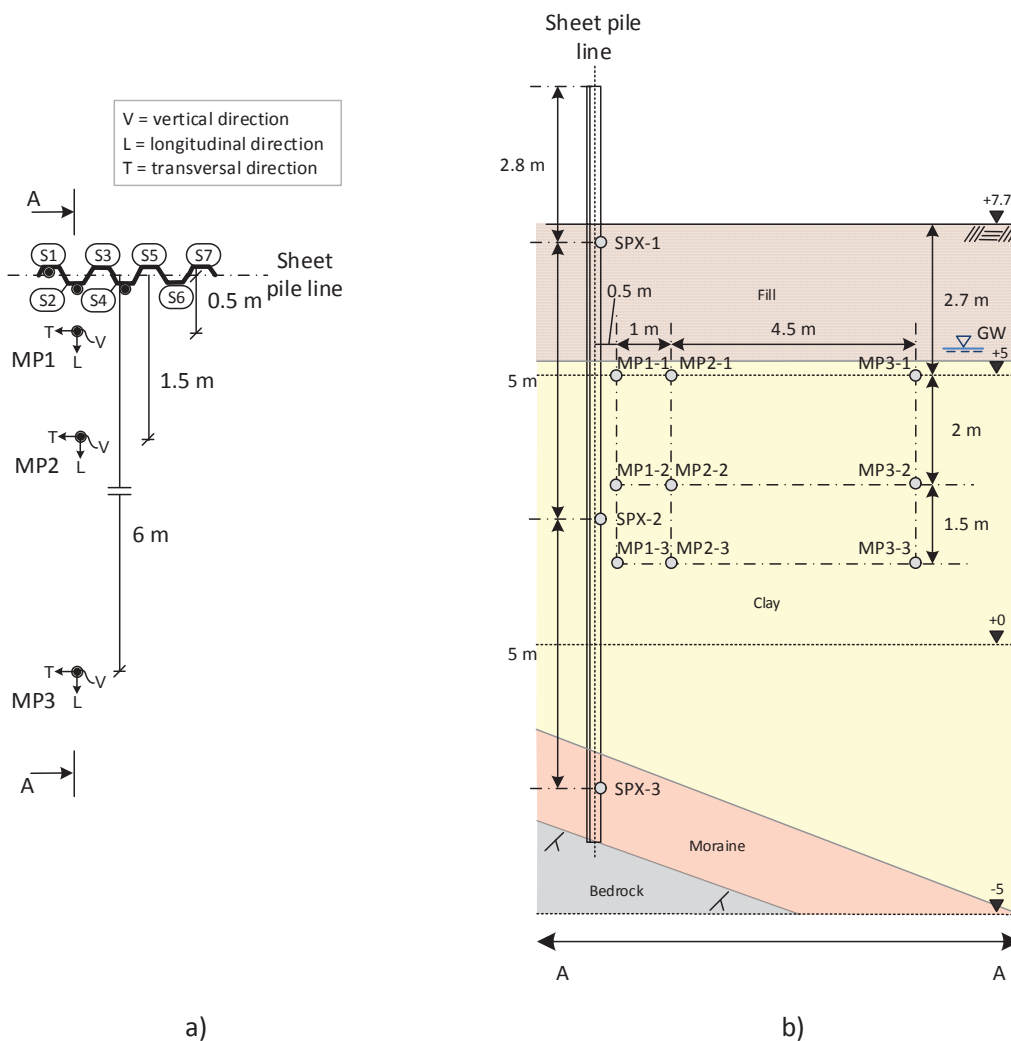

Figure 3.7 Measurement layout and characteristic soil profile of the Solna tramway field test in plan view (a) and side view (b).



Figure 3.8 Photo of driving equipment and the driving of sheet pile S1 in the Solna tramway field test.

3.4.3 Main results

A brief summary follows of the main results from the Solna tramway field test.

Results from the sensors attached to the driven sheet piles verified previous studies by Viking (2002) and Whenham (2011), showing that the sheet pile vibrates extensively in both vertical and horizontal directions. Furthermore, it was shown that up to 99% of the vibration amplitude was lost from the sheet pile to the sensors in MP1.

From recordings on sheet piles that were already installed, when driving sheet piles further along the wall, it was noted that vibrations are to a great extent transferred to adjoining sheet piles during driving in interlock, as described in Section 2.3.2.

Recordings from the sensors positioned in the soil gave information regarding wave patterns at depth. The main features were that the signals resemble P- and S-waves, originating from both sheet pile shaft and toe. Another observation was that the wave patterns become more disorderly as the distance from the sheet pile increases.

Further results from the Solna tramway field test are presented in Papers IV and V and in Guillemet (2013).

3.5 VÄRTA HARBOUR

3.5.1 Introduction

The instrumentation system that was developed was used by two master thesis students in a field test the following year, with the aim of investigating the difference in vibration between vibratory driven sheet piles and drilled RD-pile wall. In this thesis only results from the vibratory driven sheet piles are presented and analysed. A full description of the field test and additional results can be found in Daniels & Lovén (2014).

The field test was performed in Stockholm's Värta harbour in May 2014. The field test was performed at a construction site for a train station for a large Swedish energy company. The contractor on site was Skanska Grundläggning. For the location of the test site and the test site layout see Figure 3.9.

3.5.2 Measurement procedure

The geotechnical condition at the site is similar to the one observed in Solna. There is fill of unknown origin, overlaying clay, on top of moraine on bedrock (see Figure 3.10). The ground water is found at level +0 m. As can be seen in Figure 3.10, the ground level varied within the test site from +1.0 m where the sheet piles were driven to +2.5 m where two of the measurement points were located.

The sheet piles were driven with an ABI TM 14/17V leader-mounted vibrator using a driving frequency of 36 Hz. The Larssen 604 sheet pile profiles were 12 m long and driven to a depth of 10 m. The sheet piles were driven as a continuation of a longer wall segment, meaning they were all driven in interlock. A photo from the field test can be seen in Figure 3.11.

The instrumentation system described in Section 3.2 was used to record vibrations on the upper part of one driven sheet pile and at three locations at the ground surface (see Figure 3.10). Ground vibrations on the surface were recorded during the driving of three sheet piles (S1, S2 and S3). Measurement points in the ground (MP1, MP2 and MP3) were located 1 m, 5 m and 7 m from the sheet pile line (see Figure 3.10). Sheet pile S2 was equipped with an accelerometer placed around 0.5 m from the sheet pile top, recording vibrations during its driving.

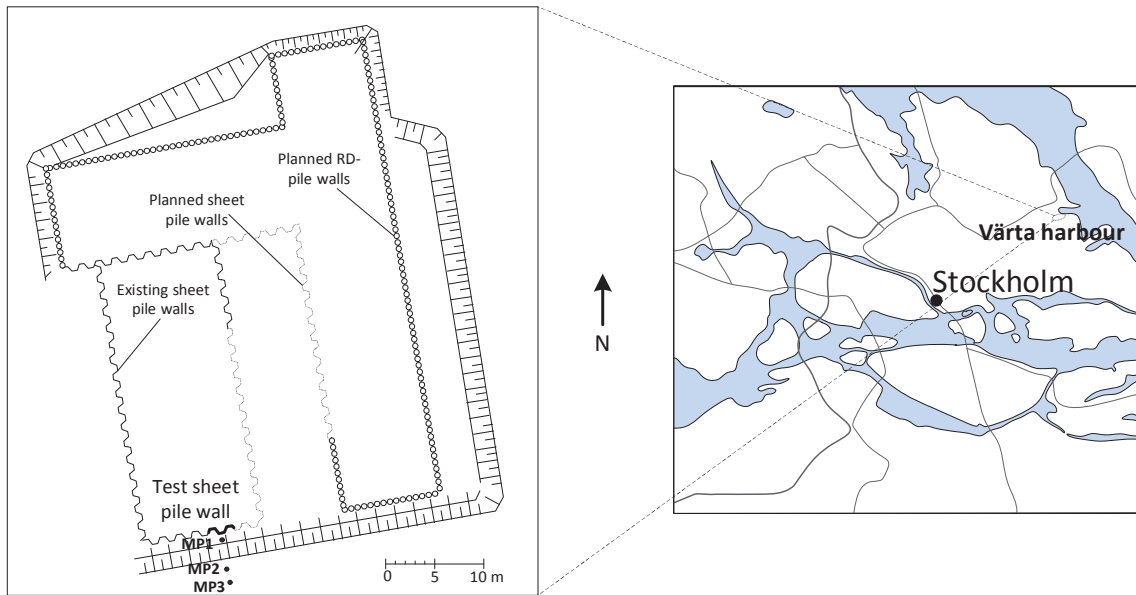

Figure 3.9 Location of Värta harbour field test in relation to Stockholm city as well as a plan view of the test site.

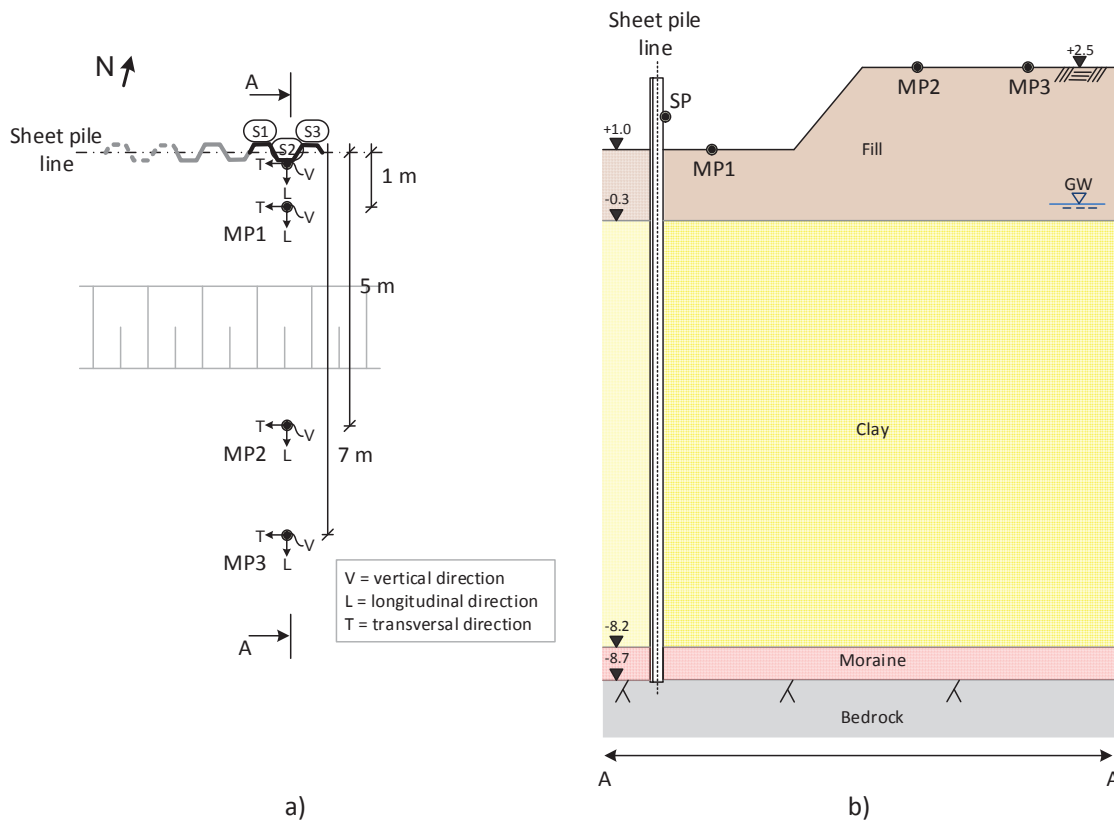

Figure 3.10 Measurement layout and characteristic soil profile of the Värta harbour field test in plan view (a) and side view (b).



Figure 3.11 Photo of driving equipment and the driving of S1 during the Värta harbour field test.

For more information regarding the measurement procedure the reader is referred to Daniels & Lovén (2014).

3.5.3 Main results

A brief summary follows of the main results from the Värta harbour field test.

Analysing results from the sensor on sheet pile S2 and in MP1 showed similar trends as those observed in the Solna tramway field test, namely that a large portion of the vibration amplitude is lost in the sheet pile-soil interface.

The main results of the wave patterns that developed in the ground showed that Rayleigh waves developed at the closest measurement point, i.e. 1 m from the sheet pile line. Moreover, the wave patterns become more disordered with increasing distance, just as they had in the Solna tramway field test. However, the analyses of the results were complicated by the rather complex geometry, where the sheet piles were driven within an excavation (see Figure 3.10).

More results from the field test have been presented in Paper V and in Daniels & Lovén (2014).

4 NUMERICAL MODELLING

4.1 INTRODUCTION

To gain a full understanding of the behaviour of the sheet pile during driving, the field tests needed to be complemented by a numerical model. The model was developed to resemble the Solna tramway field test as much as possible in terms of geotechnical conditions, sheet pile properties and load conditions. The numerical model was developed using COMSOL Multiphysics® software. A summary of the main characteristics of the numerical model is given in Table 4.1.

Table 4.1 Summary of the main characteristics of the developed numerical model.

Type of numerical model	FE
No. of dimensions	3D
Software	COMSOL Multiphysics®
Type of solver	Direct (Pardiso)
Material model	Linear elastic (steel and bedrock) and nonlinear elastic – Hyperbolic law (fill, clay and moraine)
Number of DOFs	~ 750 000
Soil profile	Fill – clay – moraine – bedrock
Domain	Frequency domain (35 Hz)
Mesh type	Free triangular, free tetrahedral and swept
Strain dependent shear modulus	Yes
Strain dependent material damping	No, geometrical damping is automatically accounted for and is the dominating damping in the model
Type of damping	Hysteretic damping (isotropic loss factor)

The main aim of the model was to enable a study to be undertaken of sheet pile behaviour during vibratory driving; however, it was also developed to serve as a platform for future development into a general model for the study of vibration transfer during vibratory sheet pile driving.

4.2 DESCRIPTION OF MODEL

The model is described in detail in Paper VI. A more general description is given below regarding the choices, assumptions and simplifications that were involved in the development of the model.

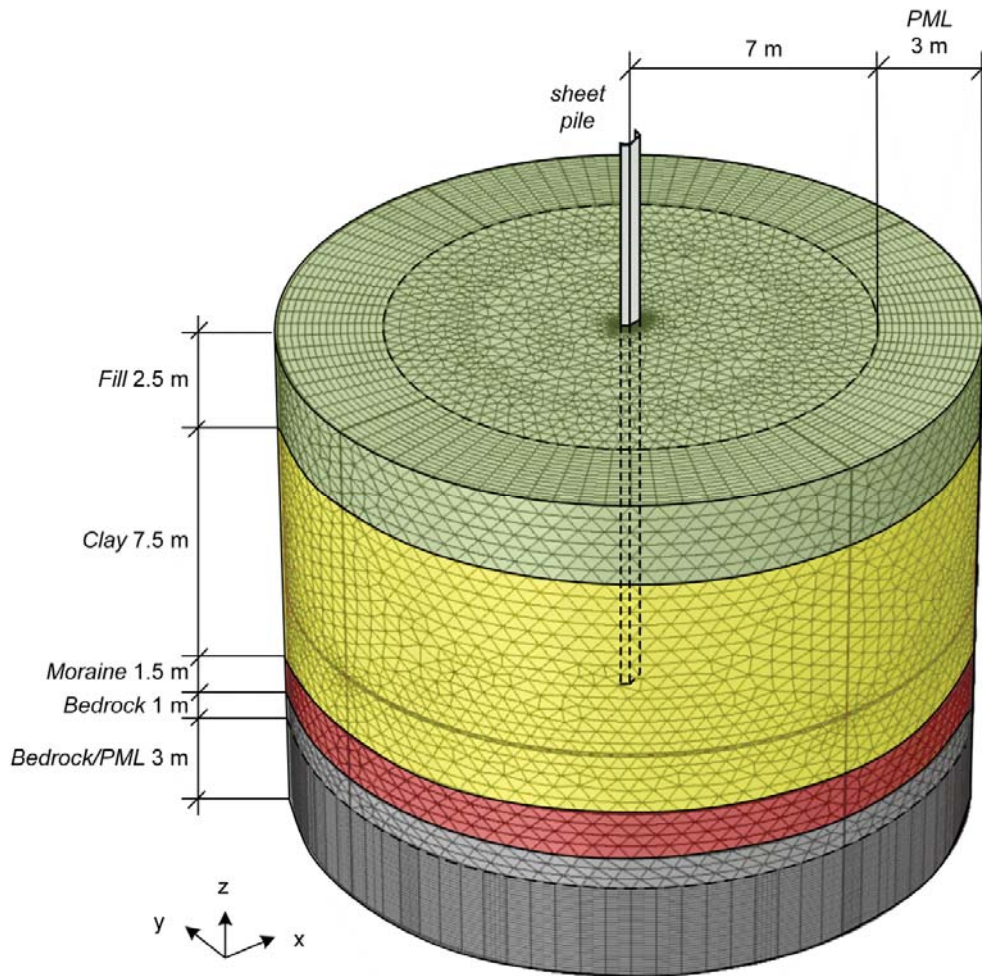

Figure 4.1 Model geometry showing soil layers, placement of sheet pile and mesh (from Paper VI).

The main aim of the numerical model was to study the behaviour of the sheet pile during driving as this has a substantial effect on the transfer of vibrations to the ground. It was therefore necessary to include parts that had been judged to be important for sheet pile behaviour, such as sheet pile geometry, eccentric placement of the load (Viking, 2002; Whenham, 2011) and behaviour of soil in close proximity to the sheet pile (Masoumi et al., 2009).

The decision to use 3D was mainly because it was hypothesised that the behaviour of the sheet pile is largely affected by its geometry and also by the eccentric placement of the load when clamping the sheet pile web. The finite element (FE) method was used since previous studies had shown promising results when modelling dynamic problems including pile driving using FE models (see e.g. Ekanayake et al. (2013)). Actual penetration is not modelled; instead the sheet pile is wished in place and calculations are made as snapshots at different depths.

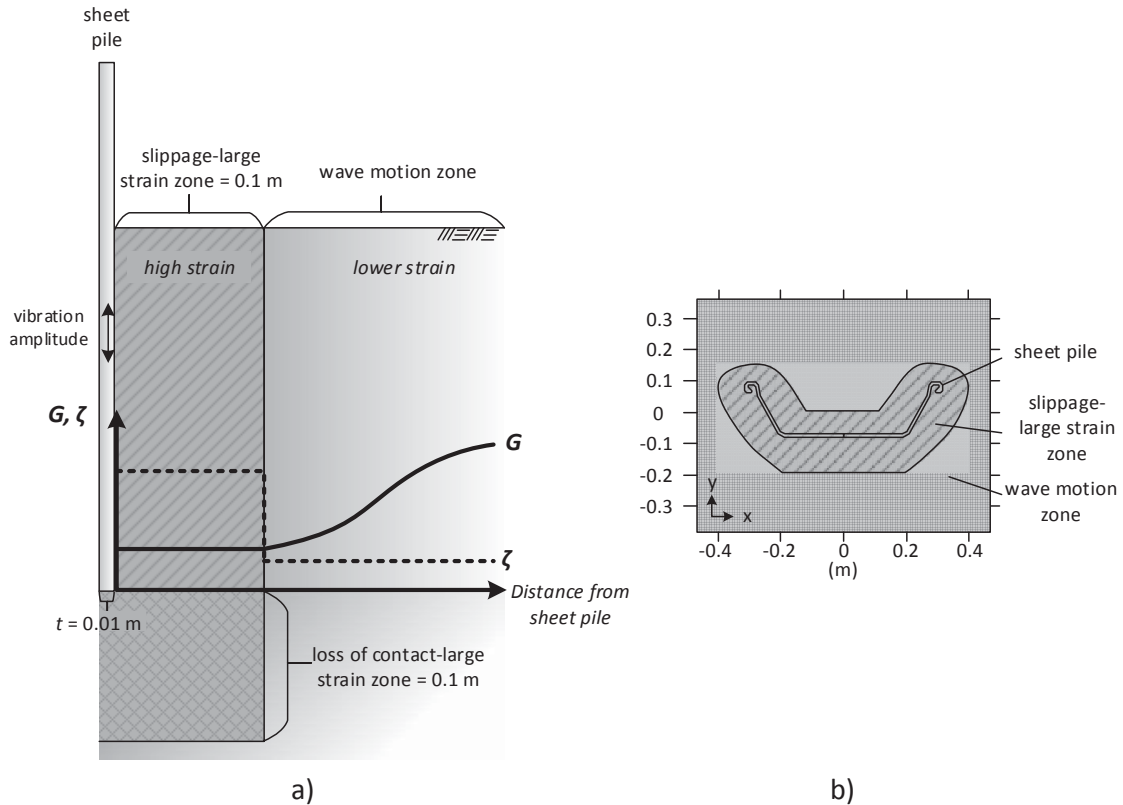

Figure 4.2 Modelling of zone in close proximity to sheet pile: a) view from the side, the development of shear modulus, G , and damping ratio, ζ , with the distance from the driven sheet pile also portrayed, and b) view from above.

True sheet pile geometry was included by importing the sheet pile geometry from a CAD drawing available from the manufacturer. The geometry was then extended to a length of 13.8 m. The soil was modelled as a cylinder consisting of three parallel layers (fill, clay and moraine) on bedrock (see Figure 4.1). The outer and bottom 3 m of the cylinder were defined as perfectly matched layers (PML), which have the ability to absorb incoming waves.

The load has been divided into a vibratory load, caused by the rotating eccentric masses (see Figure 2.3) and an added mass corresponding to the weight of the vibrator and the clamp. To see the effects of eccentric clamping, i.e. clamping the web, calculations were performed both when load was placed only on the middle part of the web (see Figure 2.4) and when it was placed over the entire sheet pile top area.

To account for the high strains induced during pile driving, Novak & Sheta (1982) presented an approach using an inner weakened zone close to the pile and a linear outer zone at a greater distance from it. This approach is modified and used in the current numerical model. The behaviour of the soil in close proximity to the sheet pile was modelled by dividing it into two zones, taking care of both slippage and the high strain levels caused by the driving. Closest to the sheet pile there is an inner weakened zone (called a slippage-large strain zone along the shaft and a loss of contact-large strain zone below the toe) with reduced shear modulus and increased damping. In Section 2.3.3 it is suggested that the shape of the zone

below the toe is actually bulb-shaped. However, in this model the zone below the toe is simplified into a continuation of the shape of the slippage-large strain zone, extending 0.1 m below the sheet pile toe. In the outer zone (called the wave motion zone) equivalent linear analysis is used, where shear modulus is dependent on shear strain level (a description of equivalent linear analysis can be found in e.g. Hardin & Kalinski (2005)). This is illustrated graphically in Figure 4.2.

In Table 4.2 the main material properties used in the model are presented. For results from the calculations using the current model the reader is referred to Paper VI.

Table 4.2 Summary of main the material properties used in the FE model for the different material models.

Material	ρ (kg/m ³)	ν (-)	G_{max}^* (MPa)	η_s^{**}
Structural steel	7850	0.33	75200	0.02
Fill	1800	0.33	40	0.08
Clay – wave motion zone	1800	0.485	Linear increase from 14 at the top to 23 at the bottom	0.04
Moraine	1900	0.485	280	0.08
Bedrock	2600	0.33	10000	0.02
Fill – slippage-simple shear zone	1800	0.33	0.035	0.4
Clay – slippage-simple shear zone	1800	0.485	0.0175	0.4
Clay – loss of contact-simple shear zone	1800	0.485	1	0.4

* In the calculations an equivalent shear modulus, G_{equ} , was used for the materials in the wave motion zone, which is a function of G_{max} and shear strain level.

**Hysteretic damping in the form of an isotropic loss factor, η_s , is used as a measure of material damping. η_s is $2*\zeta$.

5 SUMMARY OF APPENDED PAPERS

5.1 INTRODUCTION

This thesis is based on six peer-reviewed papers, which are presented in order reflecting the steps taken to acquire knowledge regarding the prediction of vibrations and the vibration transfer process during vibratory sheet pile driving. How the papers are linked together is described in Chapter 1 and Figure 1.1. This chapter presents a brief summary of each appended paper.

5.2 PAPER I

Ground vibrations due to pile and sheet pile driving – prediction models of today

Deckner, F., Viking, K. and Hintze, S. (2012). Ground vibrations due to pile and sheet pile driving – prediction models of today. In *Proceedings of the European Young Geotechnical Engineers Conference* (Wood, T. and Swahn, V. (eds)). Swedish Geotechnical Society, Gothenburg, Sweden, pp. 107-112. *Peer-reviewed conference paper.*

This paper presents a review of existing models for the prediction of ground vibration levels at a certain distance from a pile or sheet pile driving operation. For the prediction of ground vibrations from pile and sheet pile driving there are roughly three different types of models: *empirical models*, *theoretical models* and *engineering models*. Empirical models are models that are based on empirical knowledge from existing measurements and experience. Theoretical models are instead based on theoretical relationships; numerical models are classified as theoretical models. Engineering models are models that mix empirical, theoretical and engineering knowledge to create a computational model. Existing models are divided into these three types and the pros and cons of the models are discussed. The paper concludes with some prerequisites for an ideal prediction model. It identifies that a fundamental quality of a prediction model is that it should be reliable in all cases where it is meant to be used. It is also important that it is relatively easy to use and that the input data is easily obtained. Furthermore, it concludes that, as of today, there is no such model. Today's models either lack reliability or require large amounts of input data, knowledge and skills as well as time and money.

5.3 PAPER II

Aspects of Ground Vibrations due to Pile and Sheet Pile Driving

Deckner, F., Viking, K., and Hintze, S. (2015). Aspects of Ground Vibrations due to Pile and Sheet Pile Driving. *Electronic Journal of Geotechnical Engineering*, Vol. 20, Bund. 19, pp. 11161-11176. *Journal paper*.

This paper reviews the vibration transfer process during pile and sheet pile driving. Vibrations due to pile and sheet pile driving are part of a complex process involving several factors that influence both vibration magnitude and frequency. An important component in understanding vibrations due to pile driving is to comprehend and understand working procedures and the influence of different factors. In this paper the vibration transfer process is divided into coherent parts. The parts are presented and discussed based on three current field tests and previously presented experience from published research. The review identifies the parts that are most important for the induced ground vibration level at a distance from the source. It concludes that the factors having the greatest impact are the *geotechnical conditions*, the *vibration generated at the source*, the *distance from the source* and the *installation method*. The geotechnical conditions have been shown to affect vibration level in the ground significantly; however, it is important to increase knowledge of how it affects ground vibration level. The vibration generated at the source is a central factor for the vibration caused by pile and sheet pile driving, but this is another area where further research is needed to investigate the actual amount of vibration transferred from the driver to the pile/sheet pile and further into the soil. The distance from the source is important as vibration propagating in the ground is subjected to both geometric and material damping and thus decays relatively quickly. Connected to this is a debate as to whether to use the slope distance (from pile toe to the point of interest) or horizontal distance (radial distance from pile to point of interest) as the correct measure of distance. The installation method is important since the vibration signals differ substantially between impact and vibratory driven piles/sheet piles.

5.4 PAPER III

Instrumentation System for Ground Vibration Analysis during Sheet Pile Driving

Deckner, F., Guillemet, C., Viking, K. and Hintze, S. (2015). Instrumentation System for Ground Vibration Analysis during Sheet Pile Driving. *Geotechnical Testing Journal*, Vol. 38, No. 6, pp. 893-905, DOI: 10.1520/GTJ20140275. *Journal paper*.

To enable the study of the transfer of vibrations from sheet pile to soil during driving it is essential to have a record of the sheet pile vibrations as well as the vibrations at depth in the surrounding soil. This paper presents the instrumentation system for vibration analysis during vibratory sheet pile driving, developed within the scope of this research project. The development, manufacturing and calibration of the system are all described in detail. The instrumentation system was then used in a full-scale field test where vibrations were

measured on the sheet pile as well as at depth in the ground. The field test, including test site characteristics and measurement procedures, is described in detail. Results from the field test are presented with the aim of investigating the effect of the position of the sheet pile toe on the ground vibrations at depth. It is shown that within a distance of about 1.6 m from the driven sheet pile the ground vibrations at depth are affected by the passing of the sheet pile toe. The results also indicate that the toe contributes to more ground vibrations than the shaft.

5.5 PAPER IV

Vibration transfer during vibratory sheet pile driving – a full-scale field test

Deckner, F., Viking, K. and Hintze, S. (2015). Vibration transfer during vibratory sheet pile driving – a full-scale field test. *Proceedings of the 6th International Conference on Earthquake Geotechnical Engineering*, 1-4 November, Christchurch, New Zealand. *Peer-reviewed conference paper*.

Vibration transfer from sheet pile to soil during vibratory driving is commonly modelled using a theory developed for impact pile driving, where the pile/sheet pile is regarded as a stiff body moving only in the vertical direction. However, field observations from the Solna tramway field test and literature published earlier show that a driven sheet pile vibrates both vertically and horizontally. The observations also show that vibrations are transferred to adjoining sheet piles in the wall segment when driven in interlock. Based on the results, it is suggested that the common vibration transfer model is modified to better capture the real behaviour of the driven sheet pile and the adjoining sheet pile wall. Along with spherical P-wave and S-wave fronts emanating from the toe and the cylindrical S-wave front emanating from the shaft, a P-wave front emanating from the shaft is added. The horizontal movement of the sheet pile will impact the soil along the shaft as it is oscillating from side to side. This impact will generate a P-wave front that will travel away from the shaft.

5.6 PAPER V

Wave patterns in the ground – case studies related to vibratory sheet pile driving

Deckner, F., Viking, K. and Hintze, S. (2016). Wave patterns in the ground – case studies related to vibratory sheet pile driving. *Geotechnical and Geological Engineering* (In review). *Journal paper*.

This paper presents wave patterns in the ground due to vibratory sheet pile driving based on results from the three field tests presented in this thesis (Karlstad theatre, Solna tramway and Värta harbour). To enable the prediction of ground vibration levels, it is important to acknowledge the wave patterns in the ground to correctly determine which attenuation model to adopt. Current knowledge regarding wave patterns during vibratory sheet pile driving is presented and discussed. The geotechnical conditions and measurement procedures of the three field tests are briefly described; the results are then presented,

focusing on an understanding of wave patterns in the ground. The results are mainly presented as particle velocity paths, which provide a view of the particle motion in the ground during a period of 1 s at different depths and at varying distances from the driven sheet pile. The results show different wave patterns in the ground. At the ground surface the wave patterns are elliptical, resembling Rayleigh waves. At depth in the soil the wave patterns are instead strongly polarised in different directions, indicating the presence of P- and S-waves. Moreover, wave patterns tend to become more irregular with increasing distance from the source.

5.7 PAPER VI

Sheet pile behaviour during vibratory driving: a numerical study based on a field test

Deckner, F., Johansson, J., Viking, K. and Hintze, S. (2016). Sheet pile behavior during vibratory driving: a numerical study. *Soil Dynamics and Earthquake Engineering* (Submitted December 2016). *Journal paper*.

In this paper a 3D finite element model of a singular vibratory driven sheet pile profile complements the results from the Solna tramway field test to explain the complex behaviour of the sheet pile. The model is unique in several ways, e.g. the model contains true sheet pile geometry as well as eccentric loading conditions and the soil is modelled using an equivalent linear model to account for shear dependency of parameters. The paper describes the development of the model along with assumptions and simplifications made. The model is verified with analytical calculations and validated with field test results. From the calculations, it can be concluded that the sheet pile bends considerably during driving. The bending mode coincides with the fourth bending mode of a beam free at one end and fixed at the other, and it is the same irrespective of penetration depth. A study of phase difference between the top, middle and toe of the sheet pile profile indicates the presence of wave propagation within the pile. This concludes that the bending of the sheet pile is mainly controlled by the sheet pile and soil properties, and not by the penetration depth. It is also shown that the bending is mainly caused by the eccentric clamping of the sheet pile. When calculations are performed with a concentric load, the bending is insignificant. Furthermore, it is shown that the bending of the sheet pile does not seem to have any effect on the ground vibration level at a distance of 5 m from the driven sheet pile when the sheet pile toe is in the clay layer.

6 DISCUSSION

6.1 INTRODUCTION

In this section, parts of the work described earlier are discussed in a wider context. Thoughts regarding the ideal prediction model are presented and how far current knowledge stands from it today is discussed. The instrumentation system that has been developed is discussed with regard to future use and potential improvement. Furthermore, lessons learned from the field tests are presented along with the possibility of future field tests. Finally, the numerical model is discussed in relation to its general application as well as its future as a prediction model.

6.2 THE IDEAL PREDICTION MODEL – HOW FAR FROM IT ARE WE?

One aim of this thesis is to create a platform for the development of a future prediction model of vibrations due to vibratory sheet pile driving. In Paper I it is stated that the criteria for an ideal prediction model are that it should be reliable, that it should be adapted for everyday use by the practising geotechnical engineer and that the input data should be readily attainable. Paper I also reviews existing prediction models and concludes that as of today there is no prediction model that fulfils the criteria for an ideal prediction model.

In Deckner (2013) the main sources of uncertainty in vibration prediction are identified with the help of a study by Waarts & de Wit (2004) and the report by Hintze et al. (1997). The main sources that have been identified are presented in the left-hand column (a) of Table 6.1. In Paper II the main factors controlling the vibration level at a distance from the source are identified (see middle column (b) of Table 6.1). The right-hand column (c) of Table 6.1 presents the criteria for an ideal prediction model as stated in Paper I.

By analysing the information in Table 6.1 an estimate can be made as to how far current knowledge is from an ideal prediction model and in what parts further work and research are required.

Table 6.1 Summary of the main sources of uncertainty in vibration prediction (a), the main controlling factors of vibration level (b) and the criteria for an ideal prediction model (c).

	a. Main sources of uncertainty in vibration prediction	b. Main controlling factors of vibration level	c. Criteria for an ideal prediction model
1	Correct determination of input data such as soil conditions and vibrator characteristics	Geotechnical conditions	Reliable
2	Simplifications and approximations in the modelling	Vibration generated at the source (i.e. to the soil)	Adapted for everyday use
3	The effect of other factors such as time, control program etc.	Distance from source	Input data readily attainable

The first point in the left-hand column (**a1**) means in practice the same thing as the last point in the right-hand column (**c3**). For the model user, there should never be any doubt as to which input data to use, e.g. shear modulus in MPa for soil conditions and the driving force in kN, etc. Another thing that is highly important if the model is to be applicable for everyday use is that the input data can be attained from standard geotechnical investigations and common vibrator data from the manufacturer. In this study, it has been shown that for characterisation of soil conditions the shear modulus is an important parameter and for the vibrator it is important to include driving frequency, dynamic weight and driving force. These are all parameters that are relatively easy to determine; the vibrator characteristics can be attained from manufacturer's tables for the vibrator in use and the shear modulus can be estimated from empirical relationships (see Paper VI).

Points **a2** and **c1** are also connected. The term 'reliable' (**c1**) includes that the uncertainties regarding simplifications and approximations in the model (**a2**) are being minimised. An example of how this uncertainty is minimised is to increase knowledge of how vibrations are transferred from the source to the point of interest in the soil. By increasing knowledge, simplifications and approximations can be justified and made less uncertain. Thus, by clarifying the vibration transfer process, this thesis helps to reduce uncertainties regarding simplifications and approximations in the model. Nevertheless, 'reliable' also means that the prediction model should give 'correct' values (somewhat on the safe side) of vibration level in the points of interest, and to ascertain that, a developed model needs to be methodically validated against measurements.

When it comes to the middle column, it has already been said that, regarding geotechnical conditions (**b1**), this study (see Paper VI) has shown that the shear modulus, along with the hysteretic damping ratio and material density, seems to give a sufficiently proper soil model to capture the transfer of vibrations. However, further validation is needed regarding these input parameters. It is also important to clarify the importance of soil layering and how well different layers in the ground need to be defined. The 'vibrations generated at the source' point (**b2**) was also discussed earlier in terms of necessary vibrator characteristics. However, the vibrations transferred to the soil also depend on the behaviour of the sheet pile during driving and the zone in the soil closest to the sheet pile. This is studied and described in detail in Paper VI, where a way of characterising the soil closest to the sheet pile is presented

and the importance of eccentric clamping on sheet pile behaviour is highlighted. The third point in the middle column (**b3**) is important when it comes to damping and attenuation of the propagating waves. If the future prediction model is based on a 3D model (such as the model in Section 4 and Paper VI), this is ‘taken care of’ by the model geometry. If the model is in 2D, it will be necessary to include the fact that the vibrations will still spread out of the plane. If the model is in some other form, it might be interesting to consider whether horizontal distance or slope distance should be used (see discussion in Paper I).

The statements in Table 6.1 that have not yet been discussed are **a3** and **c2**. The first (**a3**) is not studied in this thesis; however, it is addressed to some extent in the latter part of this section. Turning to **c2** (‘adapted for everyday use’), it means that the use of the model should take a reasonable amount of time, and it should be simple enough so that an engineer with knowledge of geotechnical engineering and sheet pile driving should be able to use it. However, this must not be confused with saying that the model has to be simple. As long as the model is robustly designed and sufficiently reliable, it could be given a user-friendly interface where the user inserts input data and gets vibration levels in return. Point **a3** is more connected with uncertainties regarding the minimisation of disturbance and damage, and it is not something that is discussed in this thesis. The discussion in this thesis is focused on an actual prediction model that can be used prior to construction. Nevertheless, when it comes to minimising disturbance on site, there are other ways to go, e.g. real-time measurements with the ability to adapt driving to reduce vibration levels. It is a solution in cases where there is a risk of exceeding vibration limits and where it would be possible to avoid exceedance by adjusting driving conditions. However, this method does not help at the planning and/or tender stage when you want to determine which installation method to use, etc.

To sum up, the ideal prediction model does not exist yet, but this thesis works as a platform for future development of such a model. The thesis has explained the vibration transfer process with the aim of reducing uncertainty. It has identified the input data required and has provided a numerical model that has potential to be developed further into a reliable prediction model with a user-friendly interface and readily attainable input data (this is further discussed in Section 6.5).

6.3 INSTRUMENTATION SYSTEM – FUTURE USE AND DEVELOPMENT?

The instrumentation system that has been developed (see Section 3.2 and Paper III) is unique in its ability to record vibrations on driven sheet piles and at the same time at various depths and distances in the ground.

The instrumentation system can be used in its current state to perform similar vibration measurements. Due to its adaptability, the measurement programs can be varied almost infinitely depending on what area of study is of interest. For example, it could be used in real-time measurements, as was discussed above, as it has the ability to present signals from the sensors in real time.

One limiting factor of the current set-up of the instrumentation system is the number of channels available for recording (32 channels in total). With some adjustments and

additional equipment, it would be possible to include more recording channels; however, that also means more data to process. Furthermore, if alternating measurement series (i.e. measuring different sensors) were to be done at short intervals, the instrumentation system would gain from improving the connections between signal cables and the signal conditioning boxes. The changing of cables is quite cumbersome at the moment.

The development of memory capacity and storage of data is rapid. It is therefore wise to constantly look for improvements in the data acquisition system. Another possibility, depending on future technical developments, is to use wireless connections instead of cables from the sensors to the data acquisition system.

A further possibility within the field of real-time measurements is the development of the Internet of Things (IoT) and artificial intelligence (AI). Perhaps, in the future, each sheet pile profile could be equipped with a sensor and be able to communicate with the driving equipment that would in turn drive the sheet pile as smoothly as possible. This could provide endless opportunities as regards both vibration mitigation and driveability.

6.4 FIELD TESTS – LESSONS AND FURTHER DEVELOPMENT?

The three field tests performed within the scope of this thesis (see Section 3) were essential to the conclusions presented in Section 7. The field tests were all different and provided valuable knowledge about different parts of the vibration transfer process. The Karlstad theatre field test (see Section 3.3) had some limitations, but still provided valuable data regarding the connection between vibration level and soil conditions, and attenuation of vibrations with distance. Moreover, it provided valuable knowledge for the development of the instrumentation system and planning of the second field test. Hence, the Solna tramway field test (see Section 3.4) was planned in more detail. It was also the first time the newly developed instrumentation system was used in a testing situation. The instrumentation system worked as expected and the field test provided high quality data regarding sheet pile-soil vibration transfer and vibration transfer within the sheet pile wall as well as information about wave patterns in the soil. The Värta harbour field test (see Section 3.5) was mainly undertaken by two master thesis students (Daniels & Lovén, 2014), who did the planning. They used the newly developed instrumentation system and I took part in the execution of the field test on site. This field test proved that the instrumentation system still worked as expected and provided useful information regarding sheet pile vibrations and wave patterns in the soil.

One lesson learned from the field tests is that rigorous planning is a must. However, it is also important that the plan is to some extent adjustable or contains alternative measures for unexpected events that can take place when you are on site. Several visits to the site prior to testing are crucial, firstly, to get to see the site live, as usually things differ from the plan drawings, and secondly, to get to know the machine operator and the other people on site with whom you will be working. Good cooperation with the site personnel is vital. It is also important that the measurement equipment is adapted for the field test aims, something we learned the importance of in the Karlstad theatre field test where in some cases only part of the driving was recorded. Another lesson learned is the importance of the video camera for post-processing. Even though you are on site and take notes during driving, it is impossible

to capture everything. With the camera, you can view the driving repeatedly for missing details. Last, but not least, field tests take much more time than expected – there are so many things that are out of your control. A wise man once said: ‘multiply the time you expect to take by π and you will get the actual time it will take’ (Kent Lindgren).

More field tests would provide even more data, which would enable even more general conclusions to be drawn. It would also be extremely interesting to perform field tests in other geotechnical conditions to see how the results differ and to establish whether any general conclusions can be drawn. If I were to plan a field test now, with the knowledge gained from the previous field tests in mind, I would go for a relatively ‘clean’ test site with few or no underground structures and no topological differences that could potentially disturb the signals. I would also make sure that an extensive geotechnical investigation is performed at the site to minimise the use of empirical relationships and engineering knowledge to determine the required parameters.

6.5 NUMERICAL MODELLING – A FUTURE PREDICTION MODEL?

Within the scope of this thesis a numerical model was developed (see Section 4 and Paper VI) containing the sheet pile and soil in three layers upon bedrock. The model was set up to replicate the Solna tramway field test and the results from that field test were used for validation. The modelling was done in the commercial software COMSOL® Multiphysics. The software functioned well for our requirements and for this type of dynamic problem. The easy access to equations it provided allowed us to make the changes we wanted to the pre-set calculation methods.

The numerical model was developed first and foremost to study sheet pile behaviour during driving. However, the model was also developed with the intention of it being developed for further study of other phenomena (such as wave propagation away from the sheet pile, the influence of varying geotechnical conditions, etc.), as well as providing a basis for a future prediction model. Even though the model replicated the Solna tramway field test, a lot of effort was put into including general relationships to facilitate adaptation to other conditions. As I see it, the numerical model has great potential for development into a future prediction model. As it is now, the model can quite easily be adapted to other conditions, but it would need more field data for validation.

Ideally, a numerical model would be placed in the cloud and the user would use some kind of app to run the calculations. The user would be able to select the desired sheet pile profile and vibrator from a list, set the driving frequency, and then provide information regarding soil layering and soil parameters. Finally, the user would decide what points were of interest and the app would give the vibration level at these points during driving. This approach would give users who are less acquainted with numerical modelling the opportunity to do reliable predictions of the induced vibration level.

7 CONCLUSIONS AND SUGGESTIONS FOR FURTHER RESEARCH

7.1 INTRODUCTION

This thesis describes the vibration transfer process, from source to soil, during vibratory sheet pile driving, focusing on enhancing understanding of the process as a whole, while also highlighting parts that need further research. This thesis is also meant to serve as a basis for future development of a reliable prediction model for vibrations due to vibratory sheet pile driving. The following section is a summary of the major findings and general conclusions of the research project. In addition, proposals for further research are subsequently included.

7.2 CONCLUSIONS

This thesis concludes that a prediction model for vibrations due to pile and sheet pile driving should be reliable and easy to use for practising geotechnical engineers. Today, no such model exists.

The vibration transfer process during vibratory sheet pile driving is crucial when it comes to performing reliable prediction. A reliable prediction model must contain the factors and parameters of the process that are most influential regarding the predicted value, i.e. the ground vibration level at a certain distance from the driven sheet pile. From Paper II it is concluded that the following factors have the greatest impact:

- vibration generated at the source
- geotechnical conditions
- distance from the source

The vibrations generated at the source contain the important aspect of sheet pile behaviour and transfer of vibrations from sheet pile to soil. Using the instrumentation system that has been developed (see Section 3.2 and Paper III), it was possible to record sheet pile vibrations during driving. The measurements showed that the sheet pile vibrates extensively both vertically and horizontally during driving. In general, the horizontal longitudinal vibration levels are 50-100% of the vertical vibration level. The numerical model that was developed, presented in Section 4 and Paper VI, enabled clarification of the sheet pile behaviour during driving. From the numerical study, it is concluded that the sheet pile bends during driving. The bending is mainly caused by the eccentric placement of load caused by clamping of the web, but initial crookedness of the sheet pile profile, incorrect vertical alignment and wave

propagation within the sheet pile might also add to the bending. Furthermore, it is shown that the vibration transfer from sheet pile to soil is mainly controlled by the disturbed soil in the zone closest to the sheet pile. In this zone, high strains, slippage and loss of contact lead to only a small portion of the vibration energy being transferred from sheet pile to soil.

Results from the literature review as well as from the field tests have shown the importance of the geotechnical conditions on the induced vibration level in the ground. Generally, higher ground vibration levels are induced when the ground around the toe of the driven sheet pile is stiff, e.g. higher vibration levels are seen when the toe penetrates an upper fill layer, a stiffer sand layer and when the toe reaches the moraine at the end of driving. However, further research is needed regarding what is the controlling soil parameter. In order to develop a reliable prediction model, it is important to be able to use the correct input parameter for the prevailing soil conditions.

The distance from the source is a major factor regarding attenuation of vibration amplitudes. To decide the correct way of quantifying attenuation, it is important to acknowledge the wave pattern in the ground during driving. In Paper V the wave pattern in the ground was studied using results from the three field tests that were presented (see Section 3). From the study, it was verified that the wave pattern at depth resembles what would be expected with an S-wave and a P-wave front emanating from the toe and an S-wave front emanating from the shaft. At the ground surface Rayleigh waves developed as close as ~0.5 m from the driven sheet pile. Due to reflection, refraction and interference of waves, the wave pattern tends to become more irregular with increasing distance from the sheet pile. This also causes attenuation not to be monotonic, but instead higher vibration levels can be seen at e.g. 10 m than at 5 m from the driven sheet pile.

The main scientific contribution of this thesis is the identification of the behaviour of the sheet pile during driving and the characterisation of the soil in the zone closest to the sheet pile during driving, which is mainly presented in Paper VI. When it comes to practical application, the greatest contribution of this thesis is the clarification of the vibration transfer process, the new instrumentation system and the development of the numerical model.

7.3 SUGGESTIONS FOR FURTHER RESEARCH

Based on the findings of this doctoral thesis, the following objectives are suggested for future research.

It was identified in Paper II that an important factor for the vibration level at a distance from the driven sheet pile is the vibration generated at the source. In this thesis, the focus has been on the transfer of vibrations from sheet pile to soil, but another important element here is the transfer of vibrations, and the loss thereof, between vibrator and sheet pile. Some research has been done on this topic (see e.g. Whenham & Holeyman (2012)). However, further research is needed to be able to correctly quantify the loss of vibration energy between the vibrator and sheet pile.

Another factor in Paper II that was pointed out as important for determining ground vibration level is the geotechnical conditions. When it comes to vibration prediction, the key

issues are what specific details of the geotechnical conditions influence the vibration level and how these could be included in a prediction model. In all three field tests presented, the effect of the geotechnical conditions on the induced ground vibration level is clear. The numerical modelling has shown the importance of shear modulus. Nevertheless, further research is needed to clarify which soil parameters are most important to best quantify the soil condition's effect on the induced vibration level to apply it correctly in a future prediction model.

The numerical model that was developed, described in Paper VI and Section 4, could be improved further; for example, it would be interesting to include parts of a sheet pile wall that had already been installed and study driving in interlock. Furthermore, the model should be tested and verified for other soil conditions to enable generalisations to be made.

The study of sheet pile behaviour presented in Paper VI showed that the sheet pile bends during driving. There seemed to be a relationship between the bending mode and the sheet pile's eigenfrequency for bending. However, there also seemed to be wave propagation within the sheet pile during driving, something which could also affect the bending behaviour. Further research is needed to clarify the cause of the bending. This could be done using the numerical model, for example, and conduct a frequency sweep. Another possibility would be to use the instrumentation system that was developed, instrument every meter of the sheet pile during a full-scale field test, and then study the phase information of the sensors.

REFERENCES

Ahlqvist, A. and Enggren, E. (2006). Impact on surrounding environment from vibro driven sheet piles. *Proceedings of TRANSVIB 2006*, Paris, France, 21-22 September 2006, pp. 317-330.

Athanasopoulos, G.A. and Pelekis, P.C. (2000). Ground vibrations from sheetpile driving in urban environment: measurements, analysis and effects on buildings and occupants. *Soil Dynamics and Earthquake Engineering*, Vol. 19, No. 5, pp. 371-387.

Athanasopoulos-Zekkos, A., Woods, R.D. and Gkrizi, A. (2013). *Effect of Pile-Driving Induced Vibrations on Nearby Structures and Other Assets*. Technical Report No. RC-1600, Michigan Department of Transportation ORBP Number OR10-046, Ann Arbor, USA.

Attewell, P.B. & Farmer, I.W. (1973). Attenuation of ground vibrations from pile driving. *Ground Engineering*, Vol. 3, No. 7, pp. 26-29.

Auersch, L. and Said, S. (2010). Attenuation of ground vibrations due to different technical sources. *Earthquake Engineering and Engineering Vibration*, Vol. 9, No. 3, pp. 337-344.

Borel, S., Gianceselli, L., Durot, D., Vaillant, P, Barbot, L., Marsset, B. and Lijour P. (2002). Full-scale behaviour of vibratory driven piles in Montoir. *Proceedings of the international conference on vibratory pile driving and deep soil compaction*, Louvain-La Neuve, Belgium, 9-10 September 2002, pp. 181-192.

Clough, G.W. and Chameau, J-L. (1980). Measured Effects of Vibratory Sheetpile Driving. *Journal of Geotechnical Engineering Division*, ASCE, Vol. 106, No. GT10, pp. 1081-1099.

Daniels, M. and Lovén, K. (2014). *Differences in ground vibrations generated from installation of bored and vibrated retaining walls – A field study*. Master of Science Thesis, Division of Soil and Rock Mechanics, KTH Royal Institute of Technology, Stockholm, Sweden.

Deckner, F. (2013). *Ground vibrations due to pile and sheet pile driving – influencing factors, predictions and measurements*. Licentiate Thesis, Division of Soil and Rock Mechanics, KTH Royal Institute of Technology, Stockholm, Sweden.

Ekanayake, S.D., Liyanapathirana, D.S. and Leo, C.J. (2013). Influence zone around a closed-ended pile during vibratory driving. *Soil Dynamics and Earthquake Engineering*, Vol. 53, pp. 26-36.

- Erlingsson, S. and Bodare, A. (1992). Vertical S waves in soil stratum over halfspace. *Soil Dynamics and Earthquake Engineering*, Vol. 11, No. 7, pp. 427-434.
- Erlingsson, S. and Bodare, A. (1996). Live load induced vibrations in Ullevi Stadium – dynamic soil analysis. *Soil Dynamics and Earthquake Engineering*, Vol. 15, No. 3, pp. 171-188.
- Feng, Z. and Deschamps, R.J. (2000). A study of the factors influencing the penetration and capacity of vibratory driven piles. *Soils and Foundations*, Vol. 40, No. 3, pp 43-54.
- Guillemet, C. (2013). *Pile-Soil Interaction during Vibratory Sheet Pile Driving – a Full Scale Field Study*. Master of Science Thesis, Division of Soil and Rock Mechanics, KTH Royal Institute of Technology, Stockholm, Sweden.
- Hardin, B.O. and Kalinski, M.E. (2005). Estimating the Shear Modulus of Gravelly Soils. *Journal of Geotechnical and Geoenvironmental Engineering*, Vol. 131, pp. 867-875.
- Head, J.M. and Jardine, F.M. (1992). *Ground-borne vibrations arising from piling*. CIRIA Technical Note 142, CIRIA, London, U.K.
- Heckman, W.S. and Hagerty, D.J. (1978). Vibrations Associated with Pile Driving. *Journal of the Construction Division*, Vol. 104, No. CO4, pp. 385-394.
- Hintze, S. (1994). *Risk Analysis in Foundation Engineering with Application to Piling in Loose Friction Soils in Urban Situations*. Doctoral Thesis, Division of Soil- and Rock Mechanics, KTH Royal Institute of Technology, Stockholm, Sweden.
- Hintze, S., Liedberg, S., Massarsch, R., Hanson, M., Elvhammar, H., Lundahl, B. and Rehnman, S-E. (1997). *Omgivningspåverkan vid pål- och spontslagning*. Pålkommisionen rapport 95, Linköping, Sweden.
- Holeyman, A. (2002). Soil Behavior under Vibratory Driving. *Proceedings of the international conference on vibratory pile driving and deep soil compaction*, Louvain-La Neuve, Belgium, 9-10 September 2002, pp. 3-19.
- Holmberg, R., Arnberg, P.W., Bennerhult, O., Forssblad, L., Gereben, L., Hellman, L., Olsson, K., Rundqvist, G., Sjöberg, C., Sjökvist, K. and Wallmark, G. (1984). *Vibrations generated by traffic and building construction activities*. Swedish Council for Building Research, Stockholm, Sweden.
- Jongmans, D. (1996). Prediction of ground vibration caused by pile driving: A new methodology. *Engineering Geology*, Vol. 42, No. 1, pp. 25-36.
- Kim, D-S. & Lee, J-S. (2000). Propagation and attenuation characteristics of various ground vibrations. *Soil Dynamics and Earthquake Engineering*, Vol. 19, No 2, pp. 115-126.

- Kouroussis, G., Conti, C. and Verlinden, O. (2013). Investigating the influence of soil properties on railway traffic vibration using a numerical model. *Vehicle System Dynamics*, Vol. 51, No. 3, pp. 421-442.
- Lidén, M. (2012). *Ground Vibrations due to Vibratory Sheet Pile Driving*. Master of Science Thesis, Division of Soil- and Rock Mechanics, KTH Royal Institute of Technology, Stockholm, Sweden.
- Martin, D.J. (1980). *Ground vibrations from impact pile driving during road construction*. Transport and Road Research Laboratory Supplementary Report 544, England.
- Masoumi, H.R., Degrande, G. & Lombaert, G. (2006). Free field vibrations due to vibratory pile driving in a layered soil medium. *Proceedings of TRANSVIB 2006*, Paris, France, 21-22 September 2006.
- Masoumi, H.M., Francois, S. and Degrande, G. (2009). A non-linear coupled finite element-boundary element model for prediction of vibrations due to vibratory and impact pile driving. *International Journal for Numerical and Analytical Methods in Geomechanics*, Vol. 33, pp. 245-274.
- Massarsch, K.R. (2004). Vibrations Caused by Pile Driving. *Deep foundations*, summer 2004 and fall 2004 (two parts).
- Möller, B., Larsson, R., Bengtsson, P-E. & Moritz, L. (2000). *Geodynamik i praktiken*. Statens geotekniska institut, Information 17, Linköping, Sweden.
- NASSPA – North American Steel Sheet Piling Association. (2009). *Retaining Wall Comparison – Technical Report*, Fairfield, USA.
- Niederwanger, G. (1999). Measurement and estimation of vibration of old buildings. *Transactions on the Built Environment*, Vol. 39, pp. 67-76.
- Novak, M. and Sheta, M. (1982). Dynamic response of piles and pile groups. *Proceedings of the 2nd International Conference on Numerical Methods in Offshore Piling*, Austin, USA, pp. 489-507.
- Ramshaw, C.L., Selby A.R. and Bettess, P. (2000). Computation of ground waves due to piling. *Proceedings of the 6th International Conference on the Application of Stress-Wave Theory to Piles*, Sao Paulo, Brazil, 11-13 September 2000, pp. 495-502.
- Selby, A.R. (1991). Ground vibrations caused by pile installation. *Proceedings of the 4th International Conference on Piling and Deep Foundations*, Stresa, Italy, 7-12 April 1991, pp. 497-502.
- Sheng, D., Eigenbrod, K.D. and Wriggers, P. (2005). Finite element analysis of pile installation using large-slip frictional contact. *Computers and Geotechnics*, Vol. 32, pp. 17-26.

- Stille, H. & Hall, L. (1995). *Vibrationer genererade av Byggnadsverksamheter – natur och krav*. Division of Soil and Rock Mechanics, KTH Royal Institute of Technology, Stockholm, Sweden.
- Svinkin, M.R. (2008). Soil and structure vibrations from construction and industrial sources. *Proceedings of the 6th International Conference on Case Histories in Geotechnical Engineering*, Arlington, USA, August 11-16 2008.
- Viking, K. (2002). *Vibro-driveability – a field study of vibratory driven sheet piles in non-cohesive soils*. Doctoral Thesis, Division of Soil and Rock Mechanics, KTH Royal Institute of Technology, Stockholm, Sweden.
- Viking, K. (2006). The vibratory pile installation technique. *Proceedings of TRANSVIB 2006*, Paris, France, 21-22 September, 2006, pp. 65-82.
- Voznesensky, E.A. and Nordal, S. (1999). Dynamic instability of clays: an energy approach. *Soil Dynamics and Earthquake Engineering*, Vol. 18, pp. 125-133.
- Vucetic, M. and Dobry, R. (1991). Effect of Soil Plasticity on Cyclic Response. *Journal of Geotechnical Engineering*, Vol. 117, No. 1, pp. 89-107.
- Waarts, P.H. and de Wit, M.S. (2004). Does more sophisticated modelling reduce model uncertainty? A case study on vibration predictions. *HERON*, Vol. 49, No. 2, pp. 119-137.
- Walker, W.E., Harremoes, P., Rotmans, J., Van der Sluijs, J.P., Van Asselt, M.B.A., Janssen, P. and Kraymer von Krauss, M.P. (2003). Defining Uncertainty – A Conceptual Basis for Uncertainty Management in Model Based Decision Support. *Integrated Assessment*, Vol. 4, No. 1, pp. 5-17.
- Westerberg, E., Massarsch, K.R. and Eriksson, K. (1995). Soil resistance during vibratory pile driving. *Proceedings of the International Symposium on Cone Penetration Testing CPT'95*, Linköping, Sweden, 4-5 October 1995, Vol. 3, pp. 241-250.
- Whenham, V. (2011). *Power Transfer and Vibrator-Pile-Soil Interactions within the framework of vibratory pile driving*. Doctoral Thesis, University of Louvain, Belgium.
- Whenham, V. & Holeyman, A. (2012). Load Transfer During Vibratory Driving. *Geotechnical and Geological Engineering*, Vol. 30, No. 5, pp. 1119-1135.
- Wiss, J.F. (1981). Construction Vibrations: State-of-the-Art. *Journal of Geotechnical Engineering Division*, Vol. 107, No. GT2, pp. 167-181.
- Woods, R.D. (1997). *Dynamic Effects of Pile Installations on Adjacent Structures*. NCHRP Synthesis 253, National Cooperative Highway Research Program, Transportation Research Board, National Academy Press, Washington D.C., USA.